

GV-IP Speed Dome

GV-SD220 User's Manual





© 2012 GeoVision, Inc. All rights reserved.

Under the copyright laws, this manual may not be copied, in whole or in part, without the written consent of GeoVision.

Every effort has been made to ensure that the information in this manual is accurate. GeoVision, Inc. makes no expressed or implied warranty of any kind and assumes no responsibility for errors or omissions. No liability is assumed for incidental or consequential damages arising from the use of the information or products contained herein. Features and specifications are subject to change without notice. **Note: no memory card slot or local storage function for Argentina.**

GeoVision, Inc.
9F, No. 246, Sec. 1, Neihu Rd.,
Neihu District, Taipei, Taiwan
Tel: +886-2-8797-8377
Fax: +886-2-8797-8335
<http://www.geovision.com.tw>

Trademarks used in this manual: *GeoVision*, the *GeoVision* logo and GV series products are trademarks of GeoVision, Inc. *Windows* and *Windows XP* are registered trademarks of Microsoft Corporation.

September 2012

Preface

Welcome to the *GV-IP Speed Dome User's Manual*.

There are two types of the GV-IP Speed Dome, **Indoor** and **Outdoor**. They are distinguished by model:

Application	Model	Firmware Version
Indoor	GV-SD220	V1.00
Outdoor	GV-SD220-S	

This *Manual* provides an overview of the GV-IP Speed Dome and its accessories. The instructions will guide you through the installation and use of the GV-IP Speed Dome as well.

Contents

Regulatory Notices	vi
Note for Connecting to GV-System	vii
Chapter 1 Introduction	1
1.1 Overview	1
1.2 System Requirements	3
1.3 Packing List	4
1.3.1 Indoor GV-IP Speed Dome Camera	4
1.3.2 Outdoor GV-IP Speed Dome Camera	5
1.4 Functional Panel	6
1.4.1 Removing the Camera Cover	6
1.4.2 Camera Interior	7
1.5 Installing the GV-IP Speed Dome	8
1.5.1 Indoor GV-IP Speed Dome: Hard-Ceiling Mount	8
1.5.2 Outdoor GV-IP Speed Dome: Wall Pendant Mount	10
1.6 Connecting the Camera	12
Chapter 2 Getting Started	13
2.1 Looking Up the IP Address	13
2.2 Accessing Your Surveillance Images	16
2.3 Configuring the Basics	17
Chapter 3 Guest Mode and Live View Panel	18
3.1 The Live View Window	19
3.2 The Control Panel of the Live View Window	21
3.3 Snapshot of a Live Video	22
3.4 Video Recording	22
3.5 Wide Angle Dewarping	23
3.6 Picture-in-Picture and Picture-and-Picture View	24
3.7 Alarm Notification	26
3.8 Video and Audio Configuration	27
3.9 Remote Configuration	28
3.10 Camera Name Display	28
3.11 Image Enhancement	28
3.12 PTZ Control	29
3.13 Visual PTZ	30
3.14 I/O Control	32
3.15 Network Status	32
Chapter 4 PTZ Control Panel	33

4.1	Preset Settings	36
4.2	Cruise Settings	37
4.3	Auto Pan Settings	38
4.4	PTZ Settings- Sequence Settings	39
4.5	PTZ Settings- Tour Settings	41
4.6	Image Settings- White Balance	43
4.7	Image Settings- Auto Exposure	44
4.8	Image Settings- Color	46
4.8	Image Settings- Mask	47
4.9	Image Settings- Other	49
4.10	PTZ Settings- Schedule	51
4.11	PTZ Settings- Other	52
4.12	System Configuration	53
Chapter 5 Administrator Mode		55
5.1	Video & Motion	57
5.1.1	Video Settings	58
5.1.2	Motion Detection	62
5.1.3	Text Overlay	64
5.2	I/O Control	65
5.2.1	Input Settings	65
5.2.2	Output Setting	67
5.3	Events & Alerts	68
5.3.1	E-mail	69
5.3.2	FTP	71
5.3.3	Center V2	73
5.3.4	VSM	75
5.3.5	Backup Center	77
5.3.6	GV-Video Gateway / GV-Recording Server	79
5.3.7	ViewLog Server	81
5.3.8	RTSP / 3GPP	82
5.4	Monitoring	83
5.5	Recording Schedule	84
5.5.1	Recording Schedule Settings	84
5.5.2	I/O Monitoring Settings	85
5.6	Remote ViewLog	86
5.7	Network	87
5.7.1	LAN Configuration	87
5.7.2	Advanced TCP/IP	89
5.7.3	IP Filter	93

5.7.4	SNMP Settings	94
5.8	Management	95
5.8.1	Date and Time Settings	95
5.8.2	GPS Maps Settings	97
5.8.3	Storage Settings	99
5.8.4	User Account	101
5.8.5	Log Information	103
5.8.6	Tools	104
5.8.7	Language	106
Chapter 6	Recording and Playback	107
6.1	Recording	107
6.2	Playback	108
6.2.1	Playback Using the Memory Card	108
6.2.2	Playback over Network	110
6.2.3	Access to the Recorded Files through FTP Server	111
6.2.4	Playback of Daylight Saving Time Events	112
Chapter 7	Advanced Applications	113
7.1	Upgrading System Firmware	113
7.1.1	Using the Web Interface	114
7.1.2	Using the GV IP Device Utility	115
7.2	Backing Up and Restoring Settings	117
7.3	Restoring to Factory Default Settings	119
7.4	Verifying Watermark	121
7.4.1	Accessing AVI Files	121
7.4.2	Running Watermark Proof	121
7.4.3	The Watermark Proof Window	122
7.5	Downloading Videos from the SD Card	123
7.5.1	Installing the GV-SDCardSync Utility	123
7.5.2	The GV-SDCardSync Utility Window	126
Chapter 8	DVR Configurations	127
8.1	Setting Up IP Cameras	128
8.1.1	Customizing Camera Settings	131
8.2	Remote Monitoring with Multi View	133
8.3	Remote Monitoring with E-Map	135
Chapter 9	CMS Configurations	137
9.1	Center V2	137
9.2	VSM	139
9.3	Dispatch Server	140

Chapter 10 Smart Device Connection.....	141
10.1 Android	142
10.1.1 Connecting to GV-IP Speed Dome	142
10.1.2 Accessing Live View.....	144
10.2 Apple	146
10.2.1 Connecting to GV-IP Speed Dome	147
10.2.2 Accessing Live View.....	148
GV-IP Speed Dome Specifications	150
Appendix	154
A. The CGI Command.....	154
B. RTSP Protocol Support.....	155
C. Settings for Internet Explorer 8	156

Regulatory Notices



FCC Notice

This equipment has been tested and found to comply with the limits for a Class A digital device, pursuant to part 15 of the FCC Rules. These limits are designed to provide reasonable protection against harmful interference when the equipment is operated in a commercial environment.

Class A

This equipment generates, uses, and can radiate radio frequency energy and, if not installed and used in accordance with the instruction manual, may cause harmful interference to radio communications. Operation of this equipment in a residential area is likely to cause harmful interference in which case the user will be required to correct the interference at their own expense.



CE Notice

This is a Class A product. In a domestic environment, this product may cause radio interference in which case the user may be required to take adequate measures.



RoHS Compliance

The Restriction of Hazardous Substances (RoHS) Directive is to forbid the use of hazardous materials of production. To meet the RoHS Directive requirements, this product is made to be RoHS compliant.



WEEE Compliance

This product is subject to the Waste Electrical and Electronic Equipment (WEEE) Directive and made compliant with the WEEE requirements.

Naming Definition

GV-System	GeoVision Analog and Digital Video Recording Software. The GV-System also refers to GV-Multicam System , GV-NVR System , GV-DVR System and GV-Hybrid DVR System at the same time.
------------------	---

Note for Connecting to GV-System

The GV-IP Speed Dome is designed to work with and record on GV-System, a hybrid or digital video management system.

1. By default, the images are recorded to the memory card inserted in the GV-IP Speed Dome. When the GV-IP Speed Dome is connected to GV-System for video management or when the Live View (Figure 3-1) is accessed through the Web browser, the recording to the memory card will be stopped and the recording will be taken control by GV-System. When the connection between the camera and GV-System is interrupted, the recording to the memory card will be resumed to back up the images on the camera. To continue recording when the live view is accessed or when it is accessed by GV-System, enable the **Record to the local storage when live view is accessed** option on Video Settings' page. See *5.1.1 Video Setting*.
2. Once the camera is connected to the GV-System, the resolution set on the GV-System will override the resolution set on the camera's Web interface. You can only change the resolution settings through the Web interface when the connection to the GV-System is interrupted.

Optional Devices

Optional devices can expand your camera's capabilities and versatility. Contact your dealer for more information.

Device	Description
GV-Mount Accessories	The GV-Mount Accessories provide a comprehensive lineup of accessories for installing the outdoor GV-IP Speed Dome on ceiling, wall corner and pole. For details, see <i>GV-Mount Accessories Installation Guide</i> on the Software CD.
In-Ceiling Installation Package	The in-ceiling package is used to install the indoor GV-IP Speed Dome by embedding the camera to the ceiling.
24V DC Power adapter	The 24V DC power adapter is designed to convert and supply DC 24V power to indoor and outdoor GV-IP Speed Dome .

Chapter 1 Introduction

1.1 Overview

The GV-IP Speed Dome (GV-SD220/GV-SD220-S) is a network PTZ camera designed for image quality and adaptability in various environments. This camera offers the image of 1080p at 30 fps, 720p at 60 fps and 20x optical zoom, capable of showing smooth live view with great detail. In low-light environments, image quality is promised with its image processing tools, such as IR cut filter (ICR), Wide Dynamic Range pro (WDR pro), Backlight Compensation and noise reduction.

Wide surveillance coverage is made possible with 360° endless panning and 90° tilting capacity. Dome movements such as Preset, Sequence, Auto Pan, Cruise and Tour can be programmed and activated by schedule. You can create multiple dome movement modes and have different modes enabled at different time slots. The GV-IP Speed Dome provides variable pan/tilt speeds ranging from a fast patrol of 460° per second to a slow ramble of 0.5° per second with 0.2° pan accuracy for fast and accurate tracking ability.

The GV-IP Speed Dome comes with an indoor model, an outdoor model and also optional mounting kits for outdoor installations on wall, ceiling and pole.

Features:

- 1/2.8" Progressive Scan CMOS sensor
- Full HD 1080p at up to 30 fps and 720p at up to 60 fps
- 20x optical zoom and 12x digital zoom
- H.264 and MJPEG video compression
- Dual streams
- IR-cut filter for day and night function
- IP66 rating (for outdoor GV-IP Speed Dome)
- 4 digital inputs, 1 relay output
- Memory card slot
- ONVIF conformant
- Auto focus
- Wide dynamic range pro (WDR pro)
- Backlight Compensation
- Image noise reduction
- Pan 360° endlessly
- Tilt from 0° up to 90°
- Preset speed at up to 460°/sec
- PTZ movement (Preset, Sequence, Auto Pan, Cruise and Tour)
- PTZ movement by schedule
- Auto and manual PTZ calibration
- Motion detection
- Privacy Mask
- 2-way audio
- Support for iPhone, iPad, Android and 3GPP
- 31 languages on Web interface

1.2 System Requirements

To access GV-IP Speed Dome functions through Web browser, ensure your PC is in good network connection and use one of the following web browsers:

- Microsoft Internet Explorer 7.x or later
- Google Chrome
- Mozilla Firefox
- Safari

Note:

1. For users of **Internet Explorer 8**, additional settings are required. For details, see *Appendix C*.
 2. With non-IE browsers,
 - A. Motion Detection, Text Overlay, two-way audio and GPS map settings are not supported.
 - B. The Play function is only available on the live view window (Figure 3-2)
 - C. RTSP streaming must be kept as enabled. For more details, see *5.3.6 RTSP / 3GPP*.
-

1.3 Packing List

1.3.1 Indoor GV-IP Speed Dome Camera

- Indoor GV-IP Speed Dome



- Hard-Ceiling Cover



- Mounting Plate

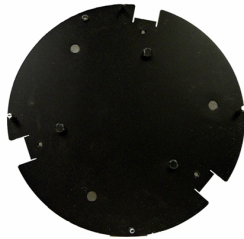

- GV-IP Speed Dome Software CD

- GV-NVR Software DVD

1.3.2 Outdoor GV-IP Speed Dome Camera

- Outdoor GV-IP Speed Dome



- Pendant Tube



- Hex Keys x 2



- M6 Screws x 3



- Desiccant pack x 2

- GV-IP Speed Dome Software CD

- GV-NVR Software DVD

1.4 Functional Panel

To access the functional panel of the GV-SD200 / GV-SD220-S, follow the section below to remove its camera cover first.

1.4.1 Removing the Camera Cover

- Indoor GV-IP Speed Dome: Rotate to remove the camera cover.



Figure 1-1

- Outdoor GV-IP Speed Dome: Unscrew using the supplied hex key



Figure 1-2

1.4.2 Camera Interior

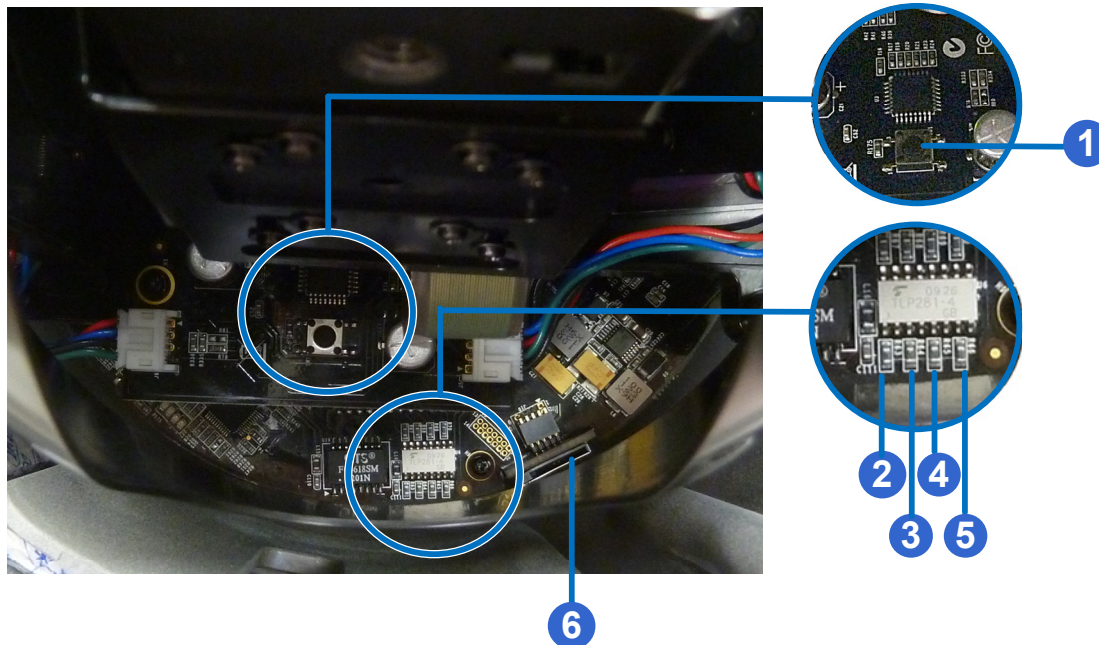

Figure 1-3

No.	Name	Function
1.	Default	Restores all the settings to the factory default values. For details see 7.3 Restoring to Factory Default Settings.
2.	Status	The status LED turns green when the power is on and fades when the camera is ready for use.
3.	Power	The power LED turns green when the power is on.
4.	ACT	The ACT LED flashes orange light upon data transmission.
5.	Link	The Link LED turns green with Internet connectivity.
6.	Memory Card Slot	Insert a micro SD/SDHC/SDXC card to store recording data.

1.5 Installing the GV-IP Speed Dome

1.5.1 Indoor GV-IP Speed Dome: Hard-Ceiling Mount



Figure 1-4

Required Items

- Indoor packing (supplied)
- ceiling screws x 3 (user-prepared)

1. Secure the mounting plate to the ceiling with self-prepared screws.

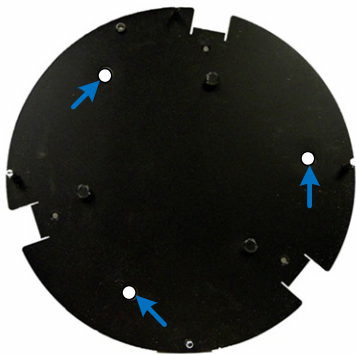

Figure 1-5

2. Secure the indoor GV-IP Speed Dome to the mounting plate.
 - A. Loosen the screw on the mounting plate

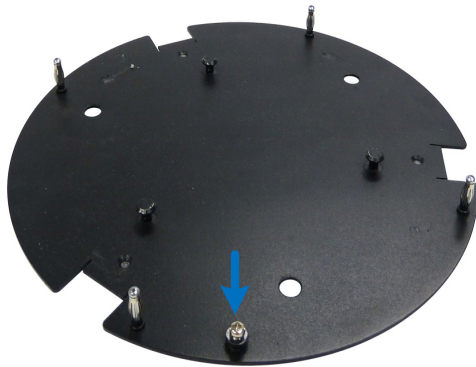

Figure 1-6

- B. Align the camera to the mounting plate and rotate the camera body to the right.

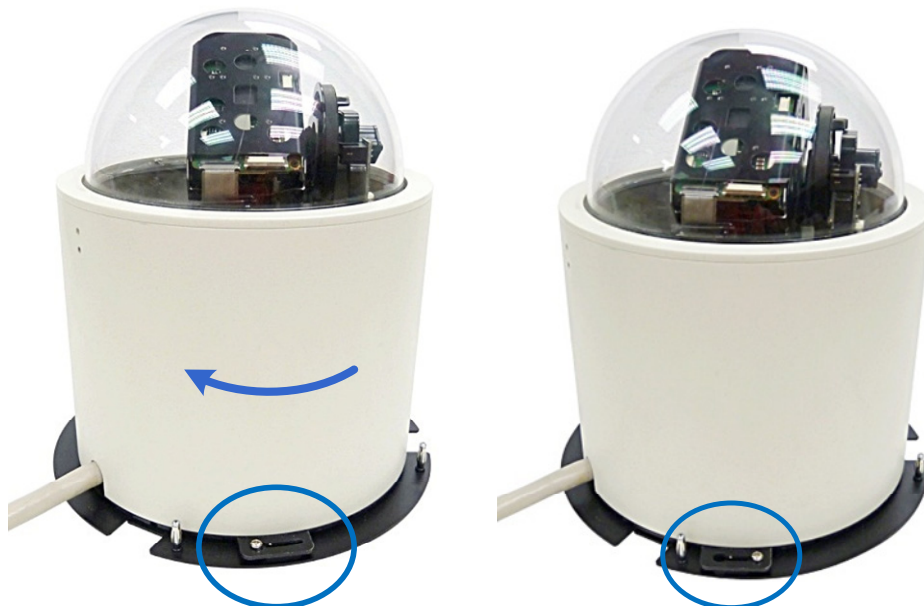

Figure 1-7

- C. Tighten the screw.
3. Put on the hard-ceiling cover.

Note:

1. Cut away a side of the cover if you want to run the cable through.
 2. You may also install the indoor GV-IP Speed Dome into the ceiling with optional mounting kits. For detail, see *GV-Mount Accessories Installation Guide* on the Software CD.
-

1.5.2 Outdoor GV-IP Speed Dome: Wall Pendant Mount



Figure 1-8

Required Items

- Outdoor packing (supplied)
- ceiling screws x 4 (user-prepared)

1. Insert the desiccant to the camera.

IMPORTANT: Be sure the desiccant is concealed in the GV-IP Speed Dome within 2 minutes of opening the desiccant pack.

- A. Remove the camera cover using the supplied hex key.



Figure 1-9

B. Unpack one desiccant and insert the desiccant to one of the indicated places.



Figure 1-10

C. Follow step 1A to secure the camera cover with the supplied hex key.

2. Thread the camera cable through the pendant tube and lock the camera to the pendant tube.
3. Secure the camera to the pendant tube with the supplied M6 screws.



Figure 1-11

4. Secure the pendant tube to the wall with self-prepared screws.

Note: You may also install the camera to ceilings, wall corners (concave or convex), and poles with optional mounting kits. For details, see *GV-Mount Accessories Installation Guide* on the Software CD.

1.6 Connecting the Camera

Follow the steps below to connect the camera. Refer to *The Data Cable* and *I/O Wire Definition* in this section for detailed information.

1. Connect a standard network cable to the Ethernet cable of the camera.
2. Connect the power adapter to the camera.
3. Optionally connect I/O devices, speaker and microphone to the camera.

The Data Cable

With the Data Cable, you can connect the power, microphone, speaker, and I/O devices to the GV-IP Speed Dome. The Data Cable is illustrated as below.

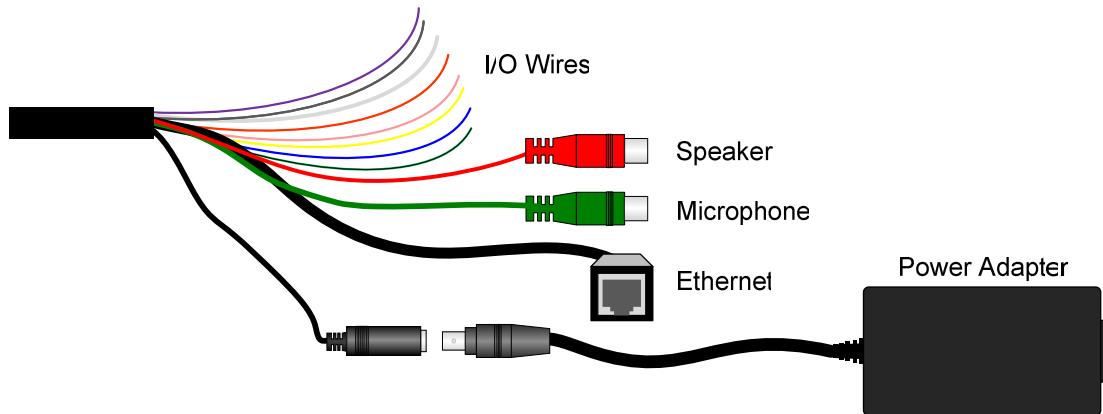

Figure 1-12

I/O Wire Definition

The I/O wires on the Data Cable allow you to connect 4 alarm input and 1 output devices. Connect the I/O devices based on the wire definition listed below.

No.	Wire	Definition
1	Orange	Alarm In 1
2	Yellow	Alarm In 2
3	Green	Alarm In 3
4	Blue	Alarm In 4
5	Pink	Ground
6	Purple	Alarm Out
7	White	Alarm Out_Open
8	Gray	Alarm Out_Close

Chapter 2 Getting Started

2.1 Looking Up the IP Address

By default, your GV-IP Speed Dome is assigned with an unused IP address by the DHCP server when the camera is connected to the network. This IP address remains unchanged unless you unplug or disconnect your camera from the network.

Note: If your router does not support DHCP, the default IP address will be **192.168.0.10**. In this case, it is strongly suggested to modify the IP address to avoid IP address conflict with other GeoVision IP device on the same LAN. To change the IP address, see *Changing the IP Address* later in this section.

Follow the steps below to check out the GV-IP Speed Dome's IP address:

1. Install the GV-IP Device Utility program from the Software CD.

Note: The PC installed with GV-IP Device Utility must be under the same LAN with the camera you wish to configure.

2. On the PC desktop, select **Start**, point to **Programs** and select **GV IP Device Utility** to execute the program. The GV IP Device Utility window appears and automatically searches for the GV IP devices on the same LAN.

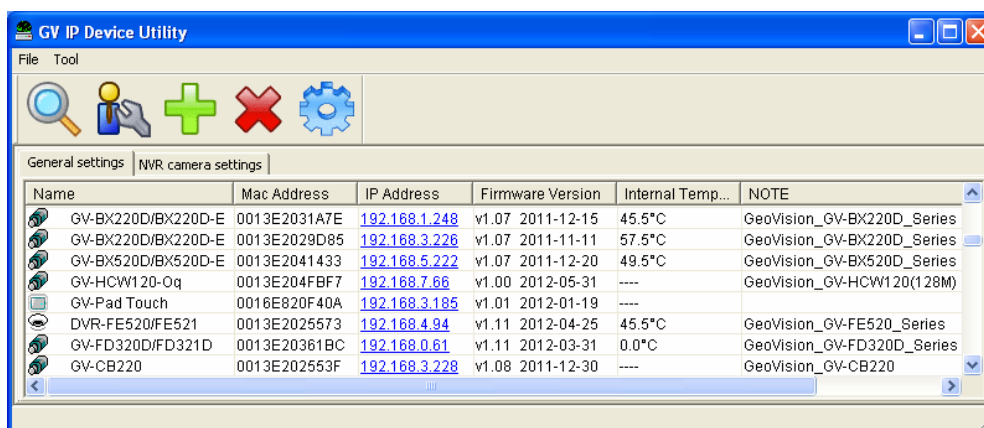

Figure 2-1

- Click the **Name** or **Mac Address** column to sort.

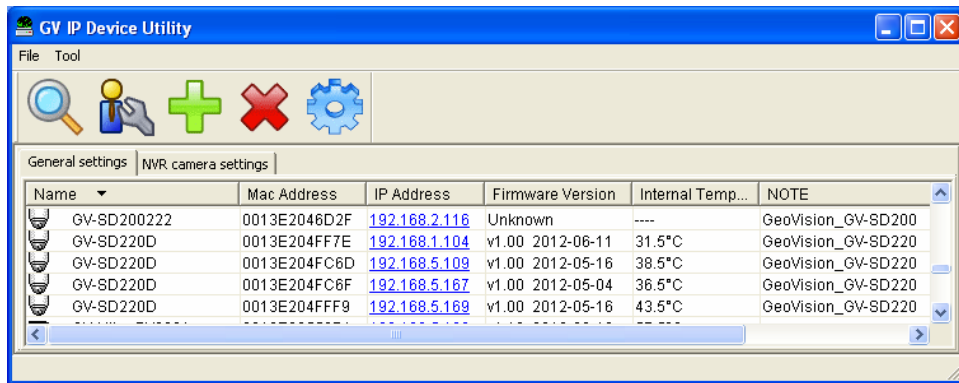

Figure 2-2

- Find the Mac Address of the camera to see its IP address.

Changing the IP Address

To modify the static IP address or set the camera to a public dynamic IP address, log in the Web interface to access the network setting page.

- Open your web browser, and type in the IP address.
 - For static network connection, type the default IP address <http://192.168.0.10>
 - For DHCP connection, follow steps in 2.1 *Looking Up the IP Address* to look up the current IP address.
- In both Login and Password fields, type the default value **admin**. Click **Apply**.
- In the left menu, select **Network** and then **LAN** to begin the network settings. This page appears.

LAN Configuration

In this section you can configure GV-IPCAM to work inside of LAN.

LAN Configuration

Dynamic IP address Select this option to obtain IP address from a DHCP server Test DHCP

Static IP address Select this option to enter a Static IP address manually

IP Address:

Subnet Mask:

Router/Gateway:

Primary DNS:

Secondary DNS: (Optional)

PPPoE Select this option to establish a DSL connection

Username:

Password:

Figure 2-3

4. Select **Dynamic IP address**, **Static IP address** or **PPPoE** and type the required network information.
5. Click **Apply**. The camera is now accessible by entering the assigned IP address on the web browser.

Important:

1. If your camera uses a public dynamic IP address via PPPoE, use the dynamic DNS Service to obtain a domain name linked to the camera's changing IP address first. For details on Dynamic IP Address and PPPoE, see *5.7.2 Advanced TCP/IP* and *5.7.1 LAN Configuration*.
 2. If **Dynamic IP Address** or **PPPoE** is enabled and you cannot access the camera, you may have to reset it to the factory default and then perform the network settings again. To restore the factory settings, see *6.3 Restoring to Factory Default Settings*.
-

2.2 Accessing Your Surveillance Images

Follow these steps to access your surveillance images:

1. Open the Internet Explorer browser.
2. Enter the IP address or domain name of the GV-IP Speed Dome in the **Location/Address** field of your browser. To look up the IP address, see *2.1 Looking Up the IP Address*.

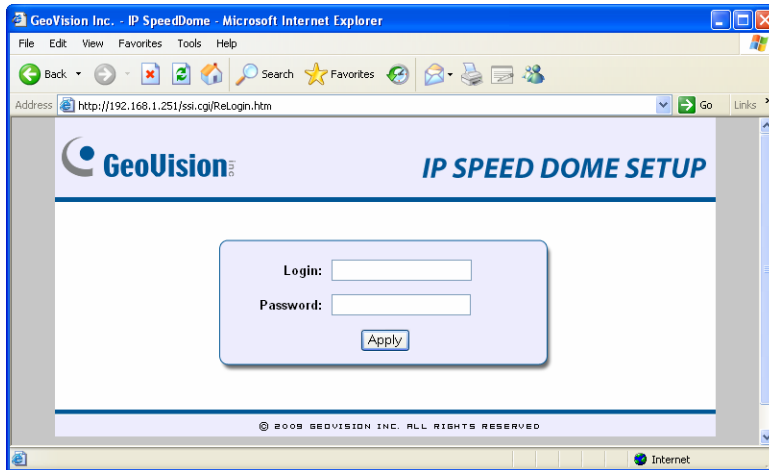

Figure 2-4

3. Enter the login name and password. The administrator account has unrestricted access to all the features and function. The guest account is restricted to accessing live view and network status information.
 - The default login name and password for Administrator are **admin**.
 - The default login name and password for Guest are **guest**.
4. A video image, similar to the example in Figure 3-1, is now displayed on your browser.

Note: To enable the updating of images in Microsoft Internet Explorer, you must set your browser to allow ActiveX Controls and perform a once-only installation of GeoVision's ActiveX component onto your computer.

2.3 Configuring the Basics

Once you have installed and logged in the GV-IP Speed Dome, you are ready to configure some of its primary settings through the Web interface:

- Date and time adjustment: see *5.8.1 Date & Time Settings*.
- Login and privileged passwords: see *5.8.4 User Account*.
- Network gateway: see *5.7 Network*.
- Camera image adjustment: see *3.2 The Control Panel of the Live View Window*.
- Video format, signal format, resolution and frame rate: see *5.1.1 Video Settings*.

IMPORTANT: If you are using a 50 Hz flicker, set the **Flicker Hz** value to **50 Hz**. See *Video Signal Type* in *5.1.1 Video Settings*.

Chapter 3 Guest Mode and Live View Panel

This section introduces the features of the guest mode and the live view window.

Main Page of Guest Mode

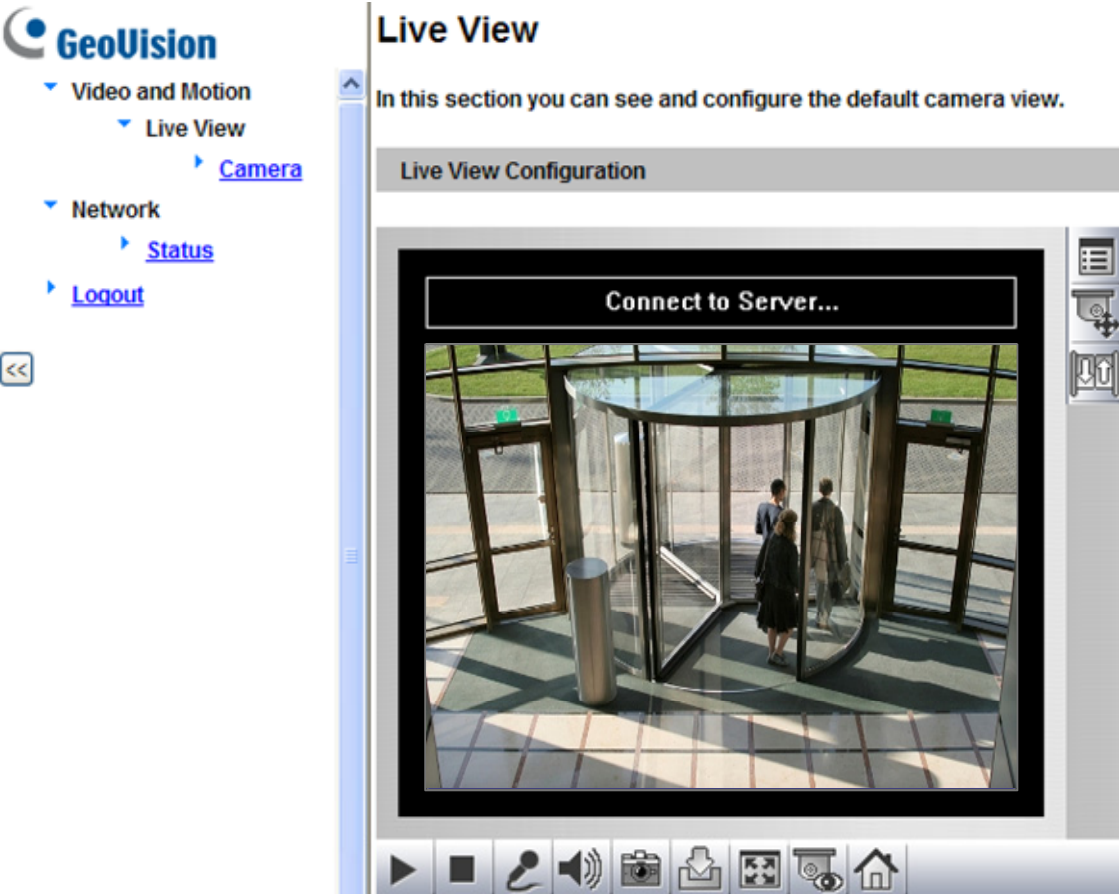

Figure 3-1

3.1 The Live View Window

In the left menu, click **Live View**, and then select **Camera** to see the live video.

Live View

In this section you can see and configure the default camera view.

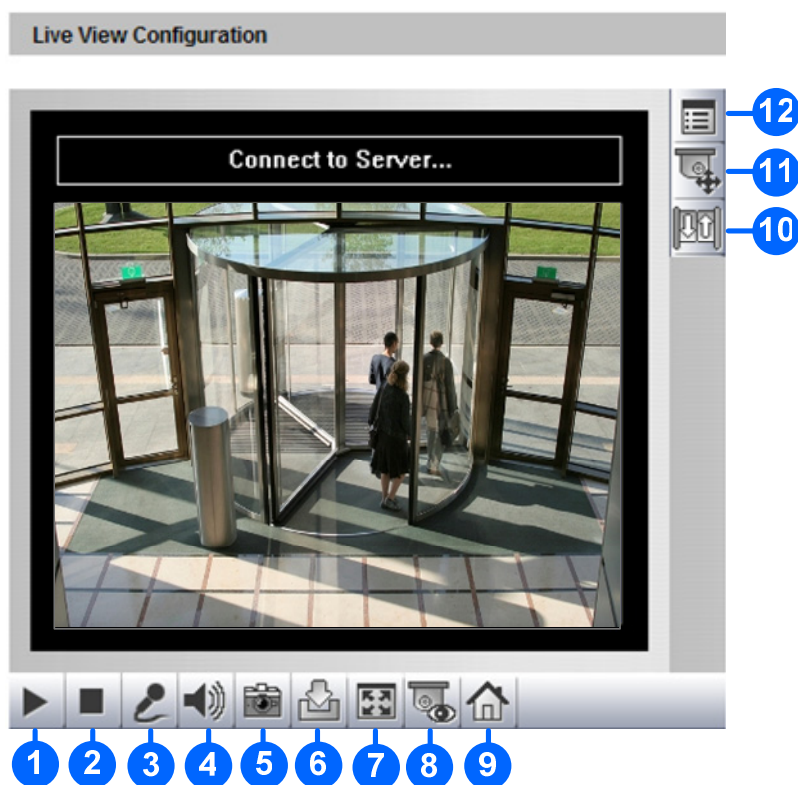

Figure 3-2

No.	Name	Function
1	Play	Plays live video.
2	Stop	Stops playing video.
3	Microphone	Talks to the surveillance area from the local computer.
4	Speaker	Listens to the audio around the camera.
5	Snapshot	Takes a snapshot of live video. --- See 3.3 <i>Snapshot of a Live Video</i> .
6	File Save	Records live video to the local computer. --- See 3.4 <i>Video Recording</i> .
7	Full Screen	Switches to full screen view. Right-click the image to have these options: Snapshot, Full Screen, Resolution, Wide Angle Lens Dewarping, PIP, PAP, GPS and Google Maps . --- See 3.6 <i>Picture-in-Picture and Picture-and-Picture View</i> .

No.	Name	Function
8	Visual PTZ	Clicks to switch to one of the three visual PTZ control modes: Fixed Direction Move, Random Move or Center Move . For details, see <i>3.13 Visual PTZ</i> .
9	PTZ Home	Click to return the dome view to the home position. To set up a home position, see <i>4.11 PTZ Settings-Other</i> .
10	I/O Control	Starts the I/O Control Panel. --- See <i>3.14 I/O Control</i> .
11	PTZ Control	Starts the PTZ Control Panel and the Visual PTZ. --- See <i>3.12 PTZ Control</i> and <i>3.13 Visual PTZ</i> .
12	Show System Menu	Brings up these functions: Alarm Notify, Video and Audio Configuration, Remote Config, Show Camera Name and Image Enhance . --- See <i>3.7 Alarm Notification, 3.8 Video and Audio Configuration, 3.9 Remote Configuration, 3.10 Camera Name Display</i> and <i>3.11 Image Enhancement</i> respectively.

3.2 The Control Panel of the Live View Window

To open the control panel of the Live View window, click the arrow button on top of the viewer. You can access the following functions by using the right and left arrow buttons on the control panel.

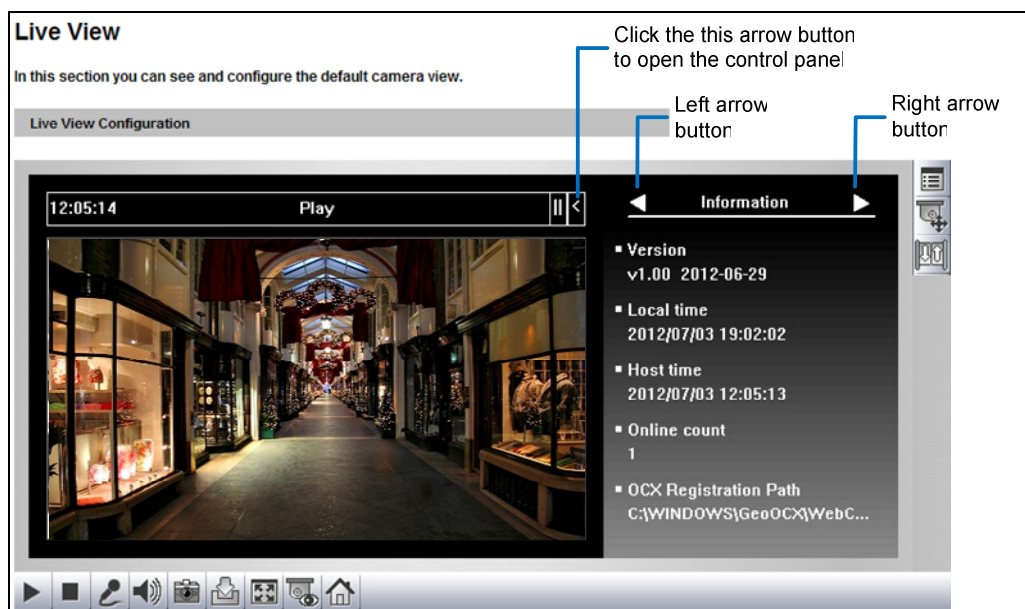

Figure 3-3

[Information] Displays the version of the GV-IP Speed Dome, local time of the local computer, host time of the GV-IP Speed Dome, the number of users logging in to the GV-IP Speed Dome and the OCX registration path.

[Video] Displays the current video codec, resolution and data rate.

[Audio] Displays the audio data rates when the microphone and speaker devices are enabled.

[I/O Control] Provides a real-time graphic display of the input and output status. You can force the output to be triggered by double-clicking its icon.

[Alarm Notify] Displays the captured images by sensor triggers and/or motion detection. For this function to work, you must configure the Alarm Notify settings first. See 3.8 *Alarm Notification*.

[GPS] Positions the GV-IP Speed Dome on Google maps. For details, see 5.8.2 *GPS Maps Settings*.

[Internal Temperature] Shows the current internal temperature of the camera and the normal temperature range.

[Download] Allows you to install programs from the hard drive.

3.3 Snapshot of a Live Video

To take a snapshot of live video, follow these steps:

1. Click the **Snapshot** button (No. 5, Figure 3-2). The Save As dialog box appears.
2. Specify **Save in**, type the **File name**, and select **JPEG** or **BMP** for **Save as Type**. You may also choose to display the camera name and/or the date, the text color and image quality for the snapshot.
3. Click the **Save** button to save the image in the local computer.

Note: You can also obtain a snapshot of the live view without logging in the user interface by executing the CGI command. See *Appendix A*.

3.4 Video Recording

You can record live video for a certain period of time to your local computer.

1. Click the **File Save** button (No. 6, Figure 3-2). The Save As dialog box appears.
2. Specify **Save in**, type the **File name**, and move the **Time Period** scroll bar to specify the time length of the video clip from 1 to 5 minutes.
3. Click the **Save** button to start recording.
4. To stop recording, click the **Stop** button (No. 2, Figure 3-2).

3.5 Wide Angle Dewarping

The live view can be curved especially near the corners. Use this function to correct the warping of live view.

1. Right-click the live view to display a drop-down list and select **Wide Angle Setting**. The Wide Angle Dewarping Setting window appears.

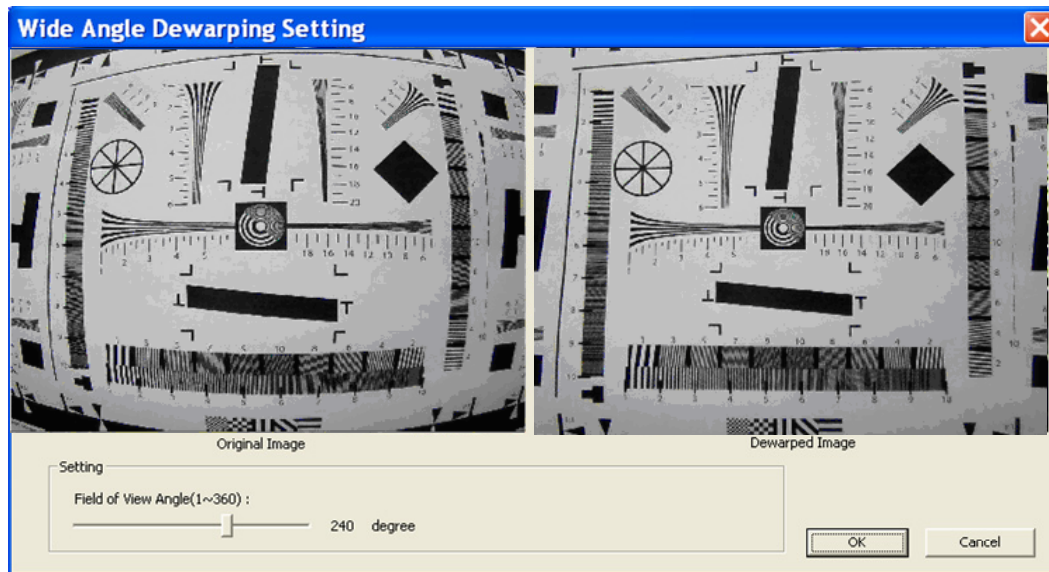

Figure 3-4

2. Move the slider at the bottom to correct the degree of warping. The adjusted view is shown on the right. Click **OK** to close this window.
3. To apply this configuration, right-click on the live view and select **Wide Angle Lens Dewarping**.

3.6 Picture-in-Picture and Picture-and-Picture View

The full screen mode provides two types of close-up views: **Picture-in-Picture (PIP)** and **Picture-and Picture (PAP)**. The two views are useful to provide clear and detailed images of the surveillance area.

Picture-in-Picture View

With the Picture-in-Picture (PIP) view, you can crop the video to get a close-up view or zoom in on the video.



Figure 3-5

1. Right-click the live view and select **PIP**. An inset window appears.
2. Click the insert window. A navigation box appears.
3. Move the navigation box around in the inset window to have a close-up view of the selected area.
4. To adjust the navigation box size, move the cursor to any of the box corners, and enlarge or diminish the box.
5. To exit the PIP view, right-click the image and click **PIP** again.

Picture-and-Picture View

With the Picture-and-Picture (PAP) view, you can create a split video effect with multiple close-up views on the image. A total of 7 close-up views can be defined.



Figure 3-6

1. Right-click the live view and select **PAP**. A row of three inset windows appears at the bottom.
2. Draw a navigation box on the image, and this selected area is immediately reflected in one inset window. Up to seven navigation boxes can be drawn on the image.
3. To adjust a navigation box size, move the cursor to any of the box corners, and enlarge or diminish the box.
4. To move a navigation box to another area on the image, drag it to that area.
5. To add, display/hide or to change the frame color of the navigation boxes, right-click the live view, select **Mega Pixel Setting** and click one of these options:
 - **Enable Add-Focus-Area Mode:** Allows the user to add navigation boxes to the image.
 - **Display Focus Area of PAP Mode:** Displays or hides the navigation boxes on the image
 - **Set Color of Focus Area:** Changes the color of the box frames.
6. To delete a navigation box, right-click the desired box, select **Focus Area of PAP Mode** and click **Delete**.
7. To exit the PAP view, right-click the image and click **PAP** again.

3.7 Alarm Notification

After input triggers and motion detection, you can be alerted by a pop-up live video and view up to four captured images.



Figure 3-7

To configure this function, click the **Show System Menu** button (No. 12, Figure 3-2), and select **Alarm Notify**. This dialog box appears.

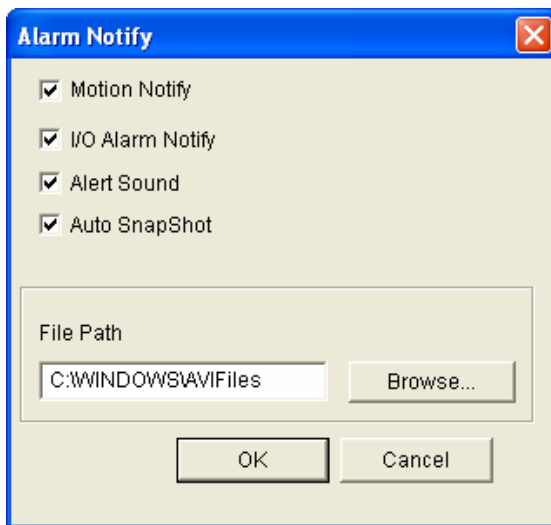

Figure 3-8

- **Motion Notify:** Once motion is detected, the captured images are displayed on the control panel of the Live View window.
- **I/O Alarm Notify:** Once the input device is triggered, the captured images are displayed on the control panel of the Live View window. For this function to work, the Administrator needs to install the input device properly. See *5.2.1 Input/Output Settings*.
- **Alert Sound:** Activates the computer alarm on motion and input-triggered detection.
- **Auto Snapshot:** The snapshot of live video is taken every 5 seconds on motion and input-triggered detection.
- **File Path:** Assigns a file path to save the snapshots.

3.8 Video and Audio Configuration

You can enable the microphone and speaker for two-way audio communication and adjust the set the number of frames to keep for live view buffer.

Click the **Show System Menu** button (No. 12, Figure 3-2), and select **Video and Audio Configuration**.

- Camera:** Sets the number of frames to keep in live view buffer. Keeping more frames for live view buffer can ensure a smooth live view, but the live view will be delayed for the number of seconds specified.

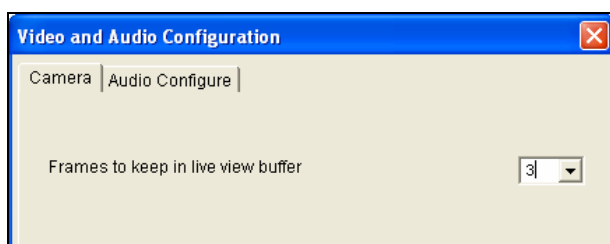

Figure 3-9

- Audio Configure:** You can enable the microphone and speaker and adjust the audio volume.

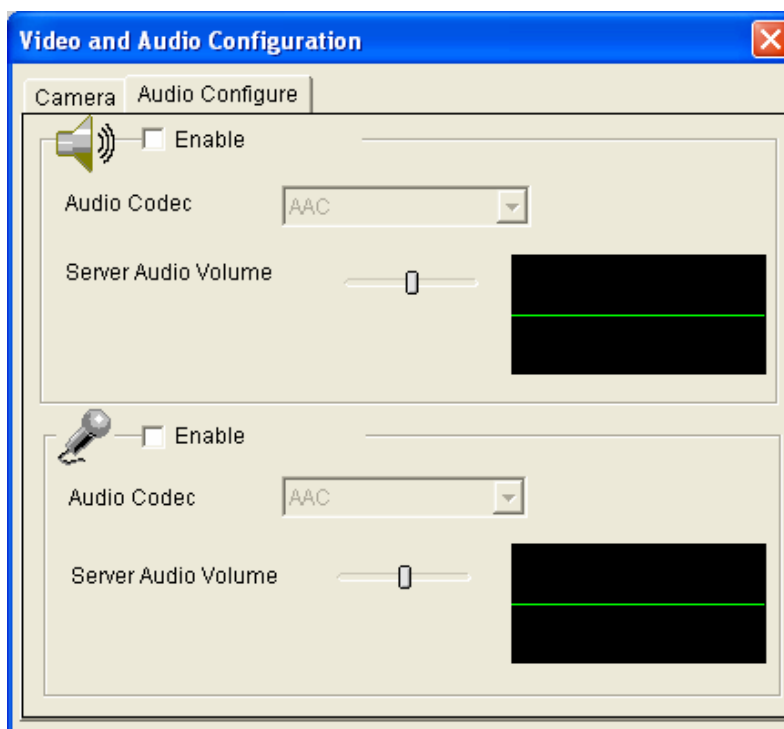

Figure 3-10

3.9 Remote Configuration

You can upgrade the device firmware over the network. Click the **Show System Menu** button (No. 12, Figure 3-2), and select **Remote Config**. The Remote Config dialog box will appear.

[Firmware Upgrade] In this tab, you can upgrade the firmware over the network. For details, see *Chapter 6 Advanced Applications*.

3.10 Camera Name Display

To display the camera name on the image, click the **Show System Menu** button (No. 12, Figure 3-2), and select **Show Camera Name**.

3.11 Image Enhancement

To enhance the image quality of live video, click the **Show System Menu** button (No. 12, Figure 3-2), and select **Image Enhance**. This dialog box appears.

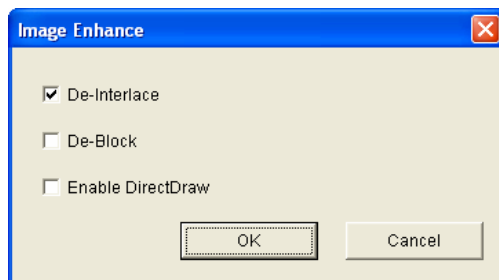

Figure 3-11

- **De-Interlace:** Converts the interlaced video into non-interlaced video.
- **De-Block:** Removes the block-like artifacts from low-quality and highly compressed video.
- **Enable DirectDraw:** Activates the DirectDraw function.

3.12 PTZ Control

The PTZ control panel is a virtual panel used to control the dome view. With the control panel, the Guest user can carry out Pan, Tilt, Zoom, Focus and Iris functions as well as pre-defined Preset, Sequence, Auto Pan, Cruise and Tour movements. In addition to these functions, the Administrator can also use the control panel to set Presets, Sequence, Auto Pan, Cruise, Tour routes and configure other PTZ settings. For setup details, see *Chapter 4 PTZ Control Panel*.

To open the PTZ Control Panel, click the **PTZ Control** button (No. 11, Figure 3-2) and select **PTZ Control Panel**.

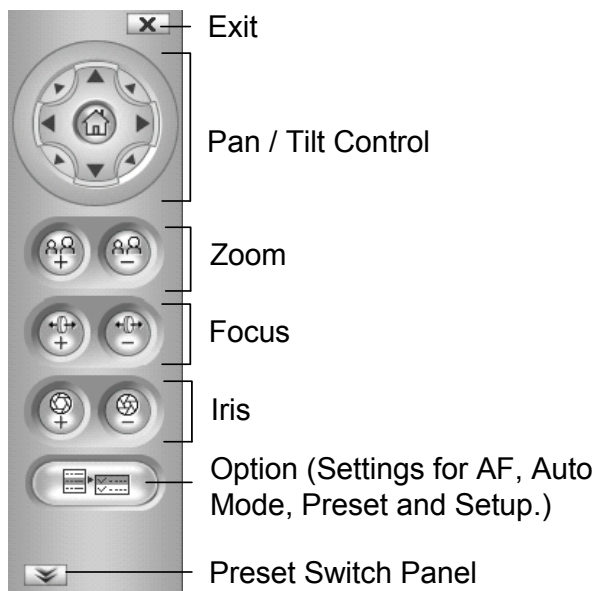

Figure 3-12

3.13 Visual PTZ

In addition to the PTZ Control Panel, you may also use a minimized panel, the visual PTZ control panel to operate your GV-IP Speed Dome. This panel can be used to perform all the functions of the guest PTZ control panel except iris control. For functions of guest PTZ control panel, see 3.12 PTZ Control.



Figure 3-13

- To access this feature, click the **PTZ Control** button (No. 11, Figure 3-2) and select **Visual PTZ** or right-click on the live view and select **Visual PTZ**.
- To change the panel settings, right-click on the live view or click the green **PTZ** button on the top left corner and select **Visual PTZ** to access the following settings:
 - **Fixed Direction Move:** In this mode, the dome view can only be moved to the eight directions (east, west, south, north, northeast, northwest, southeast and southwest). To move the dome view, click and hold on to the dotted red line of the desired direction. To move the dome view faster, click and hold on the dotted red line further from the panel. The round panel only appears when moving the mouse to the live view.
 - **Random Move:** In this mode, you can move the dome view to any direction. Click any place on the live view for the panel to appear, and right-click for the panel to hide. To move the dome view, click and hold on to a desired direction. Click further for the dome view to move faster.
 - **Center Move:** In this mode, you can zoom in and out using the mouse scroll or by drawing a block directly on the live view.

- **Set Color:** Changes the color of the panel. Three kinds of colors are available: **Red, Green** and **Blue**.
- **Transparent Degree:** Adjusts the transparency level of the panel. Ten levels range from 10% (fully transparent) to 100% (fully opaque).

3.14 I/O Control

The I/O Control window provides real-time graphic displays of camera and I/O status, and alarm events. Additionally, you can force output to be triggered.

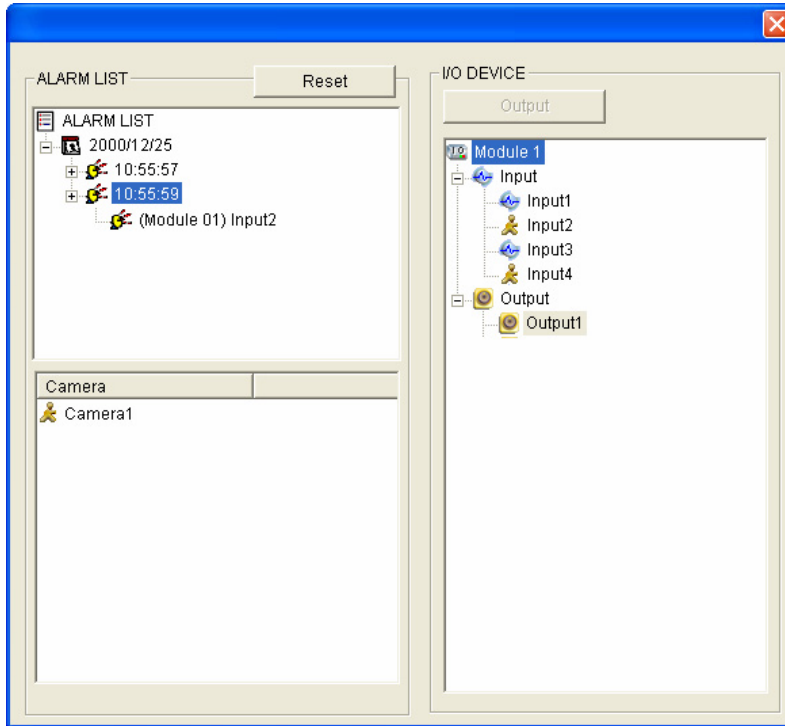

Figure 3-14

- To display the I/O control window, click the **I/O Control** button (No. 8, Figure 3-2).
- The Alarm List is displayed in three levels. The first level indicates date, the second indicates time, and the third indicates alarm ID. Clicking the **Reset** button will clear the list.
- To trigger an output device, highlight an output and then click the **Output** button.

3.15 Network Status

To view the network status, in the left menu, click **Network** and select **Status**.

Network Status Information	
In this section you can see an overview of IP SpeedDome status.	
Current Status Information	
Interface:	Wired
IP Acquisition:	Fixed
MAC Address:	0013E2016407
IP Address:	192.168.1.251
Subnet Mask:	255.255.254.0
Gateway:	192.168.0.1
Domain Name Server 1:	192.168.0.1
Domain Name Server 2:	192.168.0.2

Figure 3-15

Chapter 4 PTZ Control Panel

In this chapter, you will be guided through setup steps for various type of dome view movements (including Preset, Cruise, Auto Pan, Sequence and Tour), image quality settings, (including white balance, exposure and color parameters), schedule settings and PTZ settings.

Calling Up the PTZ Control Panel:

Click the **PTZ Control** button (No. 11, Figure 3-2) on the Live View window and select **PTZ Control Panel**. The PTZ Control Panel appears.

The figure below illustrates the functions included in the **Option** button of the PTZ Control Panel. The **Auto Go** option includes the controls of cruise, sequence and auto pan. The **Setup** option allows the Administrator to adjust the camera's parameters.

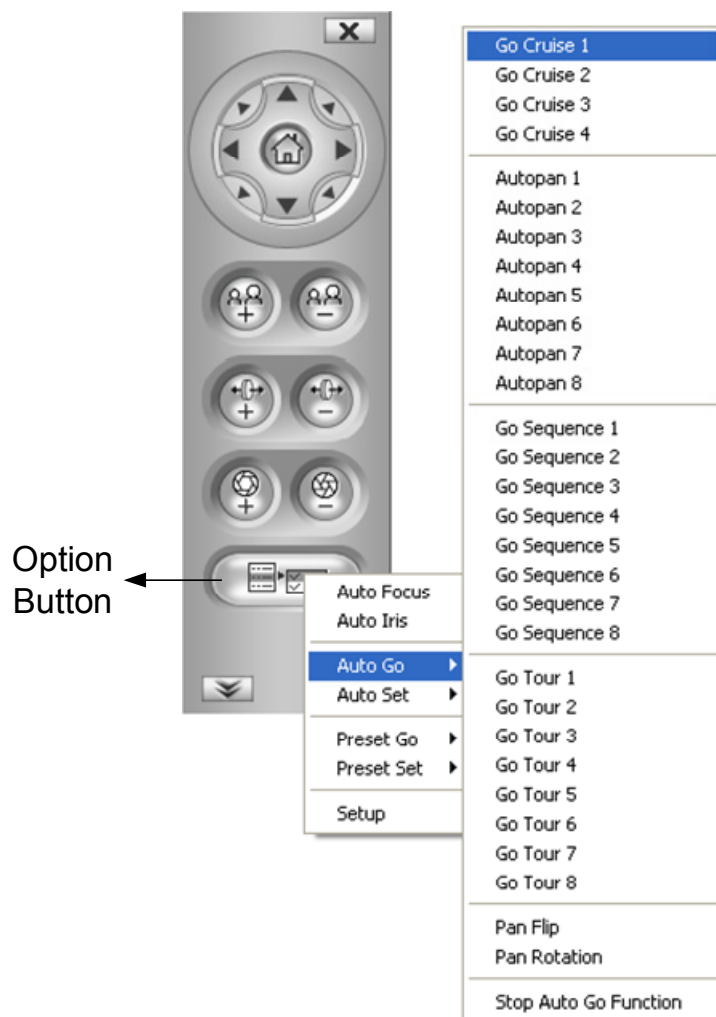

Figure 4-1

Accessing the PTZ Configuration Dialog Box:

From the PTZ control panel (Figure 4-1), click **Option** and select **Setup**. This dialog box appears.

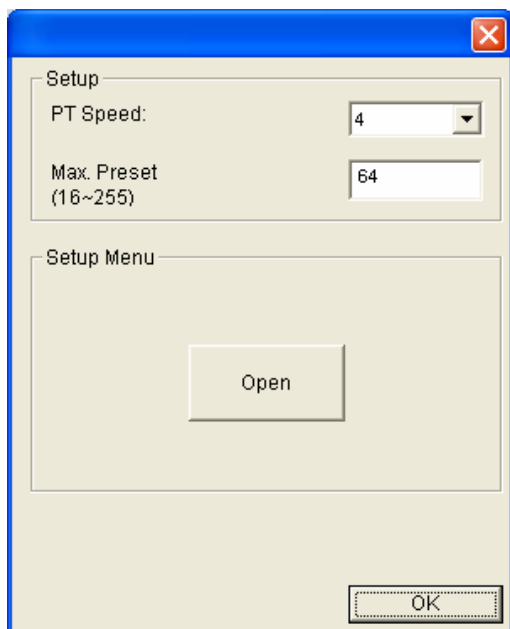

Figure 4-2

- **PT Speed:** determines the speed of panning and tilting of the dome view. The drop-down list contains 5 speed settings: 1 is the slowest speed and 5 the fastest speed.
- **Max Preset:** determines the number of Preset points for configuration. The valid range is from 16 to 255 points.

- **Start Menu:** Click Open to open PTZ configuration dialog box which contains Image Settings, PTZ settings and general settings related to PTZ function.

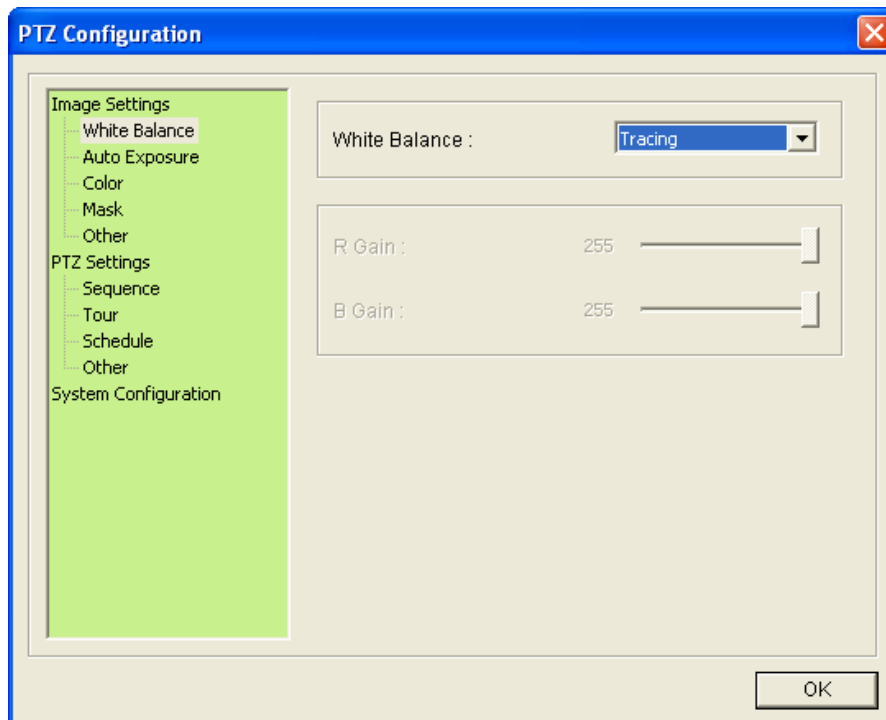

Figure 4-3

Click **OK** to save and exit the setup.

4.1 Preset Settings

You can set up a preset position toward which the dome view moves. Up to **255** preset points can be configured and saved.

Setting Up a Preset

1. To set up a preset position, use the Pan/Tilt Control keys on the PTZ Control Panel to move the dome to a desired position in Live View.
2. To save the preset position, click **Option** (Figure 4-1) on the PTZ Control Panel, click **Preset Set**, and select the desired preset number.
3. To create more preset positions, repeat Steps 1 and 2, and select a different preset number.

Using a Preset

To move the dome view to a previously defined preset position, click **Option** (Figure 4-1) on the PTZ Control Panel, click **Preset Go**, and select a **Preset** number which has been set up.

4.2 Cruise Settings

You can set up a route consisting of different directions, angles, and zooms for the GV-IP Speed Dome to follow. Up to 4 Cruises can be created.

Setting Up a Cruise

1. Click **Option** (Figure 4-1) on the PTZ Control Panel, click **Auto Set** and select **Set Cruise 1**.
2. Use Pan/Tilt Control keys and zoom in / out keys to set the desired route path and zoom.
3. When you are finished with setting up a Cruise 1 route, click **Option** (Figure 4-1), click **Auto** and select **Set Cruise Stop**.
4. To set up another Cruise route, repeat Steps 1 to 3, and select a different Cruise number.

Starting and Stopping a Cruise

To start the GV-IP Speed Dome on a defined Cruise route, click **Option** (Figure 4-1) on the PTZ Control Panel, click **Auto Go** and select a **Go Cruise** number which has been previously set.

To stop a Cruise route in action, click on a Pan/Tilt Control key, home key, zoom button or focus button on the PTZ Control Panel.

4.3 Auto Pan Settings

The GV-IP Speed Dome can pan up to 360° endlessly to survey the horizontal view between 2 user-defined positions. You can configure up to 8 sets of Auto Pan mode.

Setting Up an Auto Pan

1. Set up the vertical position of your GV-IP Speed Dome first. The vertical direction set during or after the horizontal movement settings will not be effective.
2. Set up the start position of the Auto Pan.
 - A. Use the Pan/Tilt Control keys and zoom in / out keys on the PTZ control panel to move to a start position.
 - B. Click **Option** (Figure 4-1) on the PTZ Control Panel, click **Auto Set** and select **Set Auto Pan 1 Start Position**.
3. Set up the end position of the Auto Pan.
 - A. Use the Pan/Tilt Control keys and zoom in / out keys on the PTZ control panel to move to an end position.
 - B. Click **Option** (Figure 4-1) on the PTZ Control Panel, click **Auto Set** and select **Set Auto Pan 1 Stop Position**.
4. To create another Auto Pan mode, repeat Steps 1 to 4, and select a different Auto Pan number.

To configure the Pan speed and the duration of dome view staying at the two positions, see *4.11 PTZ Settings- Other* in this manual.

Note: The zoom ratio of an Auto Pan's Start Point will persist throughout the whole path.

Starting and Stopping an Auto Pan

To start the GV-IP Speed Dome on an Auto Pan mode, click **Option** (Figure 4-1) on the PTZ Control Panel, click **Auto** and select an **Auto Pan** number which has been previously set. An enabled Auto Pan will repeat until it is stopped by clicking a Pan/Tilt Control key, home key, zoom button or focus button on the PTZ Control Panel.

4.4 PTZ Settings- Sequence Settings

You can have the dome view move in a series of predefined movements, called a Sequence. Create a Sequence by linking a number of presets points. Up to 8 Sequences can be created and a minimum of 2 preset points must be selected for a Sequence route to work.

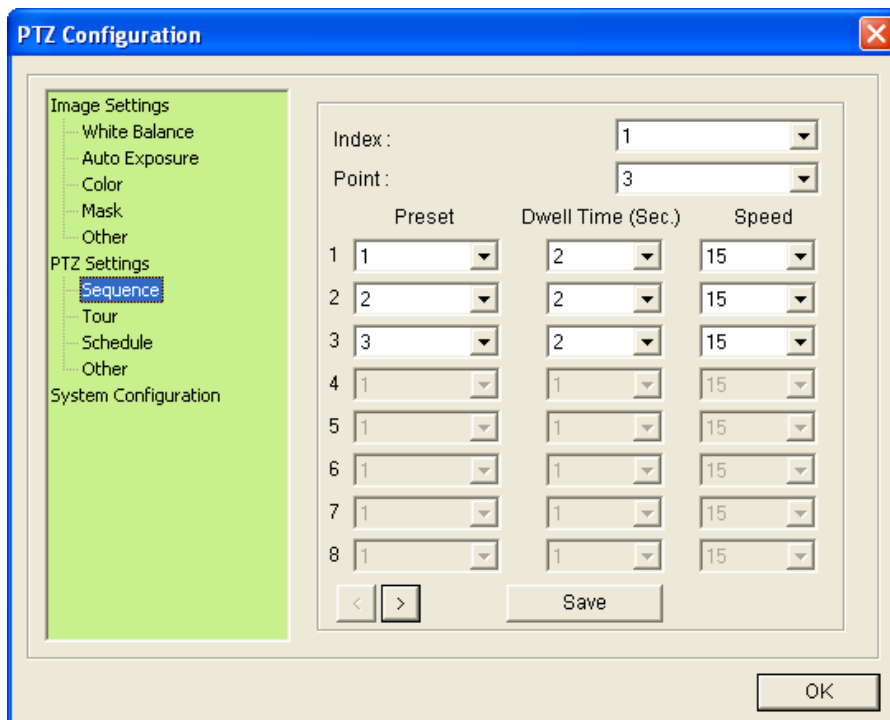

Figure 4-4

Setting Up a Sequence

1. Follow the steps in *Accessing the PTZ Configuration Dialog Box* above and click **Open** to display the **PTZ Configuration** dialog box, click **Sequence** located under **PTZ Setting** on the left menu.
2. Use the **Index** drop-down list to select the Sequence group number to be configured. Up to 8 Indexes (Sequence groups) can be created.
3. One Sequence group can include up to 16 Preset Points. Use the **Point** drop-down list to select the number of Preset Points allowed in this Sequence group.
4. Use the **Preset** drop-down list to select the Presets for this Sequence group.
5. Use the **Dwell Time** drop-down list to set the duration for the dome to stay at this Preset. The duration time ranges from 1 to 255 seconds.
6. Use the **Speed** drop-down list to set the speed at which the dome travels from one Preset to another.
7. To create another Sequence group, repeat Steps 1 to 6, and select a different Index number.
8. Click **Save** to complete the settings.

Starting and Stopping a Sequence

To start the dome view on a Sequence route, click **Option** (Figure 4-1) on the PTZ Control Panel, click **Auto Go** and select a **Go Sequence** number which has been previously set. The dome view will continue moving once a Sequence is started. To stop the movements, click a Pan/Tilt Control key, home key, zoom button or focus button on the PTZ Control Panel.

4.5 PTZ Settings- Tour Settings

You can set up your GV-IP Speed Dome to move in a combination of preset positions, Sequence, Cruise and Auto Pan. You can configure up to 8 Tour routes.

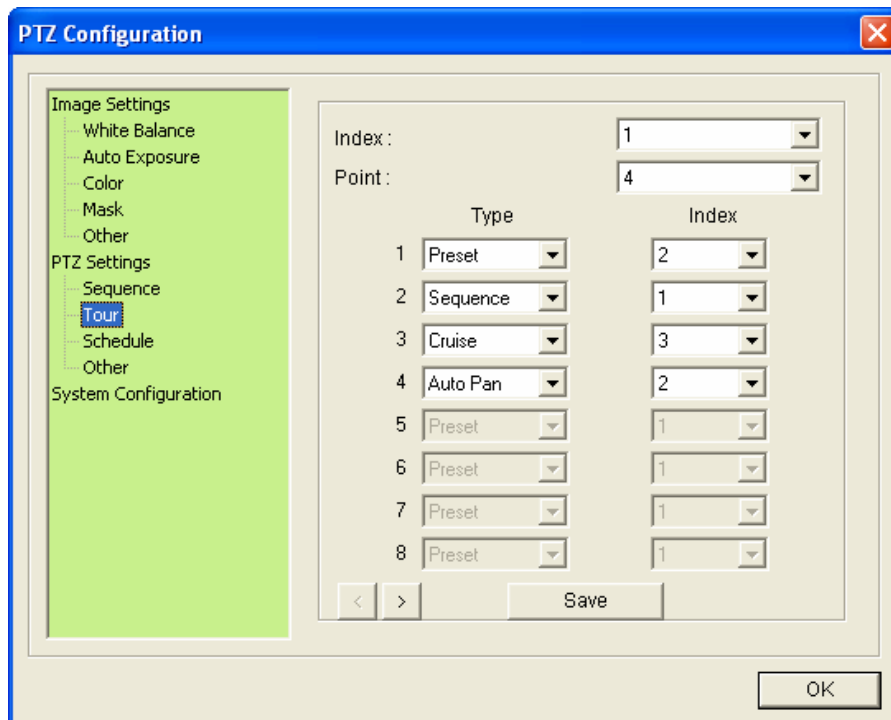

Figure 4-5

Setting Up a Tour

1. Follow the steps in *Accessing the PTZ Configuration Dialog Box* above and click **Open** to display the **PTZ Configuration** dialog box, click **Tour** located under **PTZ Setting** on the left menu.
2. Use the **Index** drop-down list to select the Tour group number to be configured. Up to 8 Indexes (Tour groups) can be created.
3. One Tour group can include up to 16 sets of Preset Points, Sequence, Cruise and Auto Pan. Use the **Type** drop-down list to select the movement type.
4. Use the **Index** drop-down list to select the movement number for each movement type.
5. To create another Tour group, repeat Steps 1 to 6, and select a different Index number.
6. Click **Save** to complete the settings.

Starting and Stopping a Tour

To start the GV-IP Speed Dome on a Tour route, click **Option** (Figure 4-1) on the PTZ Control Panel, click **Auto Go** and select a **Go Tour** number which has been previously set. An enabled Tour will repeat until it is stopped by clicking a Pan/Tilt Control key, home key, zoom button or focus button on the PTZ Control Panel.

4.6 Image Settings- White Balance

The White Balance setting is used to adjust the colors of camera image so that it reflects normal coloring under different environment lighting.

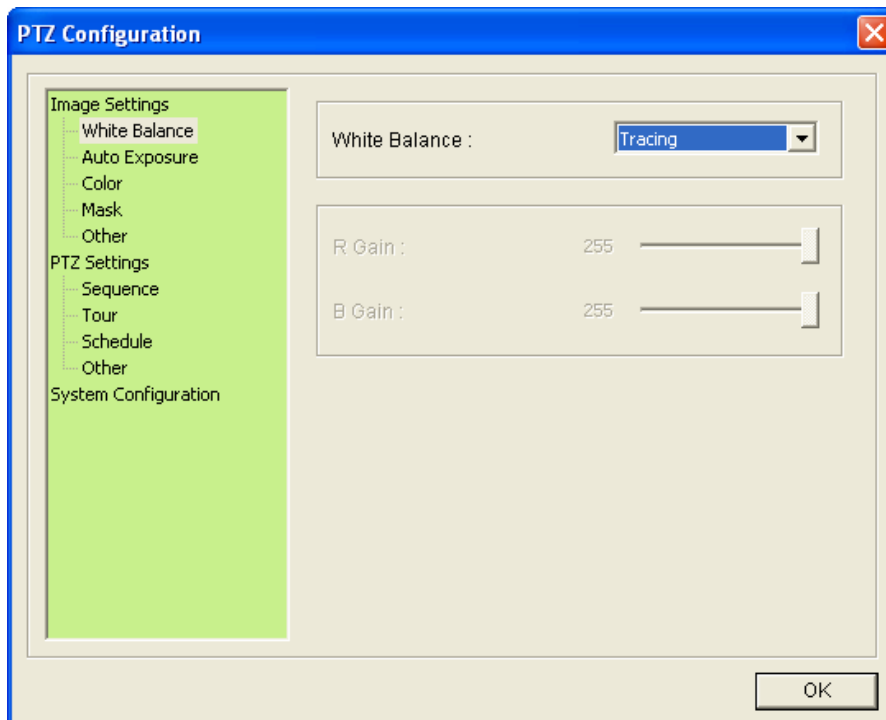

Figure 4-6

- **Auto:** The camera automatically performs color adjustments. This option is suitable for environments with unchanging lightings.
- **Indoor:** This option is designed to adjust the colors of an indoor scene.
- **Outdoor:** This option is designed to adjust the colors of an outdoor scene.
- **One Push:** Once enabled, the camera adjusts its colors for one time.
- **Tracing:** The camera adjusts constantly for the correct color balance. This option is suitable for environments with changing lightings.
- **Manual:** The White Balance values can be manually changed by moving the sliders to adjust **R Gain** (red color of images) and **B Gain** (blue color of images) values.

4.7 Image Settings- Auto Exposure

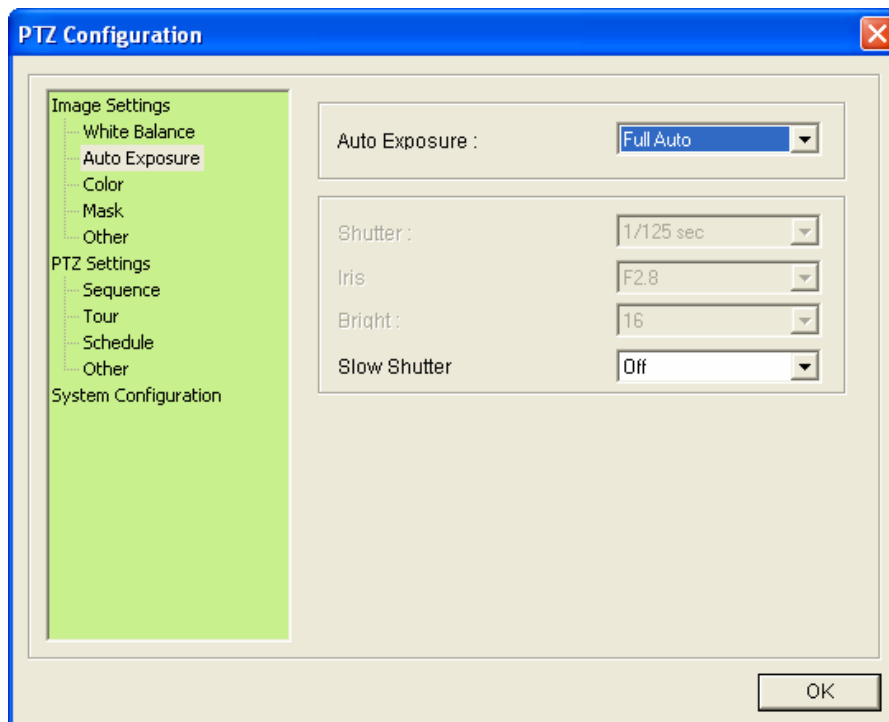

Figure 4-7

- **Auto Exposure:** provides controls on camera exposure. Select **Full Auto**, **Shutter Priority**, **Iris Priority** or **Bright Priority**. The default is **Full Auto**.
 - **Full Auto:** The camera adjusts its exposure automatically. By enabling this option, you can also adjust the **Slow Shutter** below.
 - **Shutter Priority:** The camera uses the specified **Shutter** speed below.
 - **Iris Priority:** The camera uses the specified **Iris** setting below.
 - **Bright Priority:** The camera adjusts its iris and AGC settings using an internal algorithm to achieve different degrees of brightness. Brightness is controlled by Gain under low-light conditions and by Iris under well-lit conditions. By enabling this option, you can also adjust the **Bright** value below.
- **Shutter:** This option is only available under the **Shutter Priority** mode for Auto Exposure. Use the drop-down list to select a shutter speed. For details see *Appendix B Shutter Speed*.
- **Iris:** This option is available under the **Iris Priority** mode for Auto Exposure. Use the drop-down list to select the iris level.
- **Bright:** This option is only available under the **Bright Priority** mode. Use the drop-down list to select a brightness value. The higher the value the brighter the image.

- **Slow Shutter:** This option is only available under the **Full Auto** mode. The shutter speed determines how long the image sensor is exposed to light. For clearer images in low light conditions, select **ON** to enable slow shutter speed.

4.8 Image Settings- Color

The Color settings are used to adjust color contrast, sensitivity and gain.

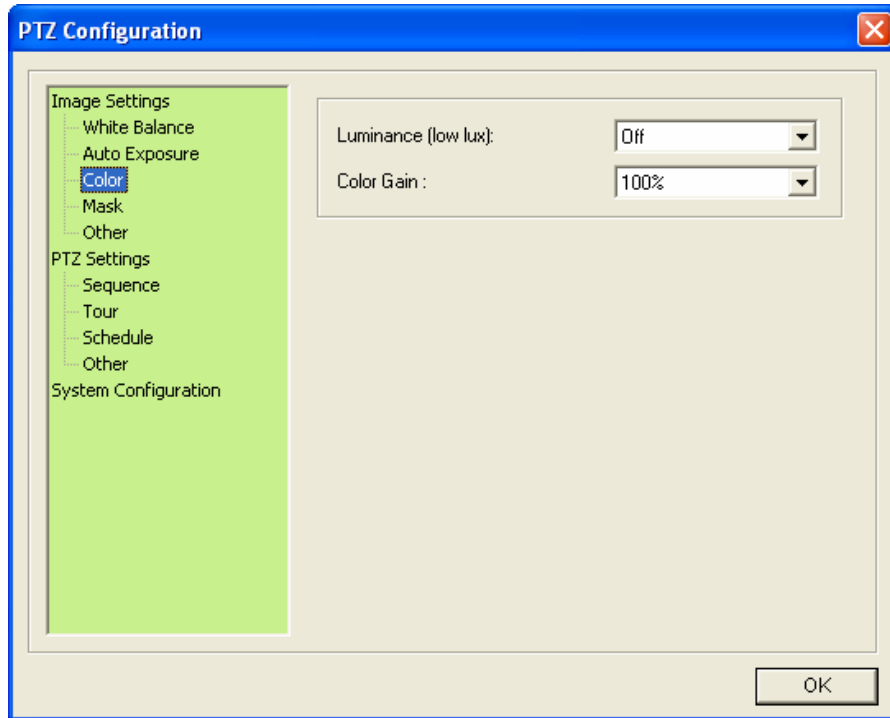

Figure 4-8

- **Luminance (low lux):** Enable this function to make low-light views clearer.
- **Color Gain:** Adjusts the contrasts of the dome view.

4.8 Image Settings- Mask

The Mask is used to block out sensitive areas from view. You can create and save up to 8 Masks. The Mask size will stay proportional to the zoom, which increases when zoomed in and decreases when zoomed out. The Mask will be fixed to the position where it is first created. This means, when the dome pans to the left, the Mask will gradually move to the right and out of the view and when the dome moves from the left back to the right side, the mask will gradually appear back into the view.

Note:

1. The Mask function is only available when the tilting angle is between 0° to 70°.
 2. It is highly recommended to set the mask area at least twice bigger (in height and width) than the object that you want to cover it with a protective mask.
-

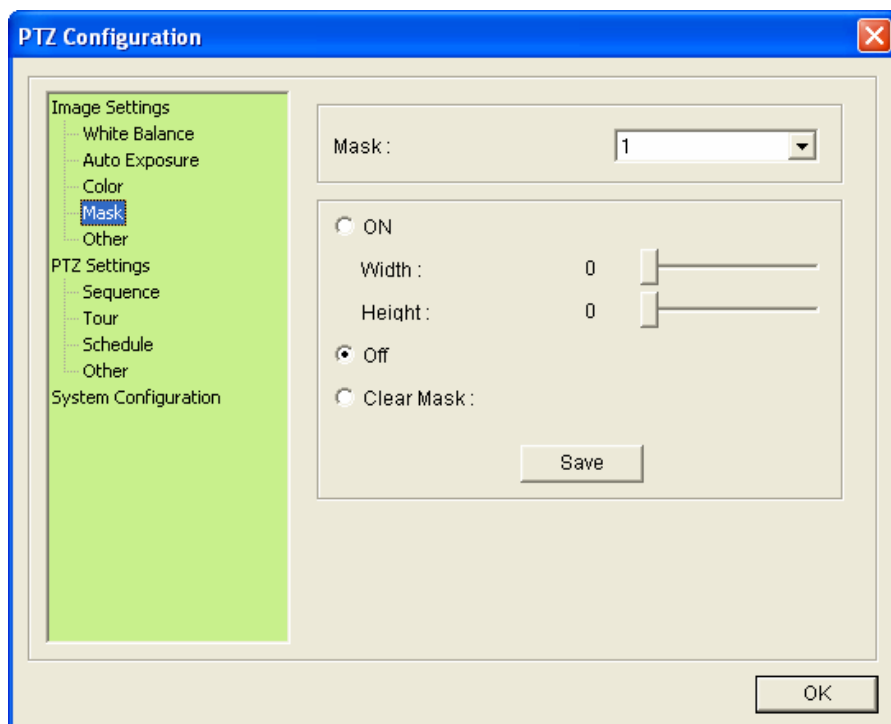

Figure 4-9

1. To create a Mask, follow the steps below.
 - A. Use the **Mask** drop-down list to select a Mask number. You can create up to 8 different Masks.
 - B. Select **ON** and use the **Width** and **Height** slider bars to set the Mask size.
 - C. Click the **Save** button to save the settings. The Mask appears at the center of the dome view.
 - D. To modify the Mask size, repeat Steps 2B and 2C.

2. To disable a Mask, select the Mask number from **Mask**, select **Off** and click the **Save** button.
3. To create a new Mask, select a different Mask number and follow steps 1B to 1D.
4. To delete a Mask, select the Mask number from **Mask**, select **Clear Mask** and click **Save** button.

4.9 Image Settings- Other

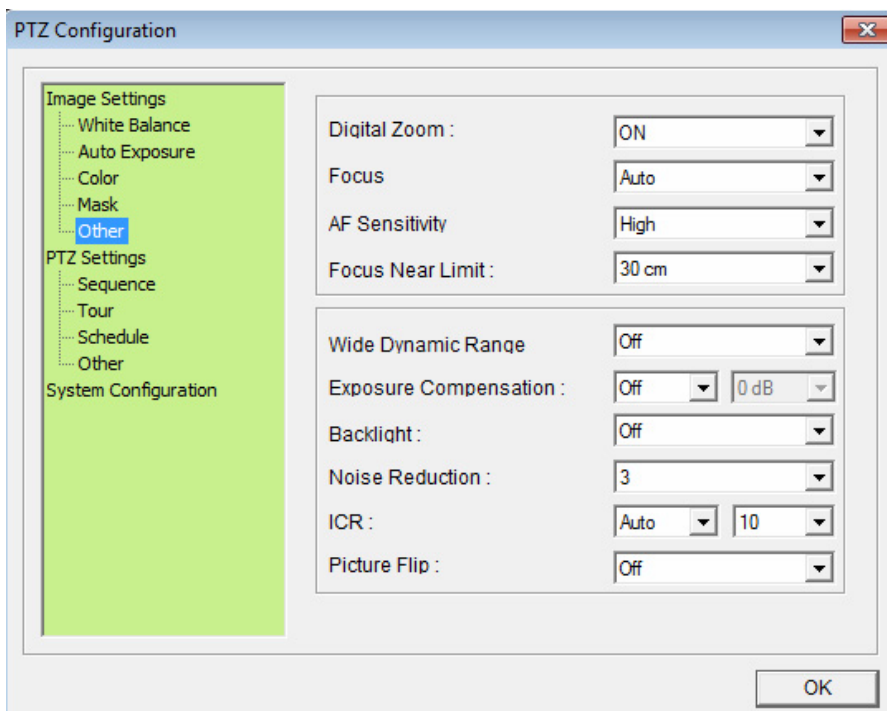

Figure 4-10

- **Digital Zoom:** With this option, users can enable or disable the 12x Digital Zoom. The Digital Zoom will be activated after the Optical Zoom level is fully reached. The default setting is **Off**.
- **Focus:** Sets the focus mode of the dome. Select **Auto** for the dome to automatically focus after scene change and PTZ movement (such as preset or any function executed from the PTZ control panel); select **Manual** for the dome to focus only once after every PTZ movement and the focus will not be adjusted even if the scene changes. The default is **Auto**.
- **AF Sensitivity:** Adjusts the speed of automatic focusing. The default setting is **High**.
- **Focus Near Limit:** Use the drop-down list to select the distance beyond which the focus can not be done. The default value is **30 cm**.
- **Wide Dynamic Range:** The Wide Dynamic Range is used to adjust scenes that contain both very bright and dark areas. This function improves scene clarity by making the dark areas more visible and at the same time keeping the clarity of the bright areas. This function is disabled by default.
- **Exposure Compensation:** Adjust the brightness for auto exposure. This function is disabled by default.

- **Backlight:** Backlight Compensation (BLC) is used to compensate AGC in adjusting color intensity. For scenes with strong light in the background and dim light in the foreground, AGC is not effective because AGC averages the light intensity of a whole frame. BLC compensates for this characteristic by restricting AGC to adjust color intensity of a specific area. This function is disabled by default. To enable this function, use the drop-down list and select **ON**.
- **Noise Reduction:** reduced image specks (noise). The default value is **3**. The higher the value, the stronger the effect.
- **ICR:** This function defines how the camera's IR-cut filter works. Select **Auto** for the camera to automatically enable or disable the IR-cut filter depending on the light conditions. Select **Day** for the camera to remain in day mode, and **Night** to remain in night mode. The default setting is **Auto**, with sensitivity level **10**.
- **Picture Flip:** Rotate the image by 180 degrees.

4.10 PTZ Settings- Schedule

You can set up a schedule for the dome to perform Preset, Sequence, Auto Pan, Cruise or Tour during a specified time. Up to 8 sets of schedule can be configured and saved.

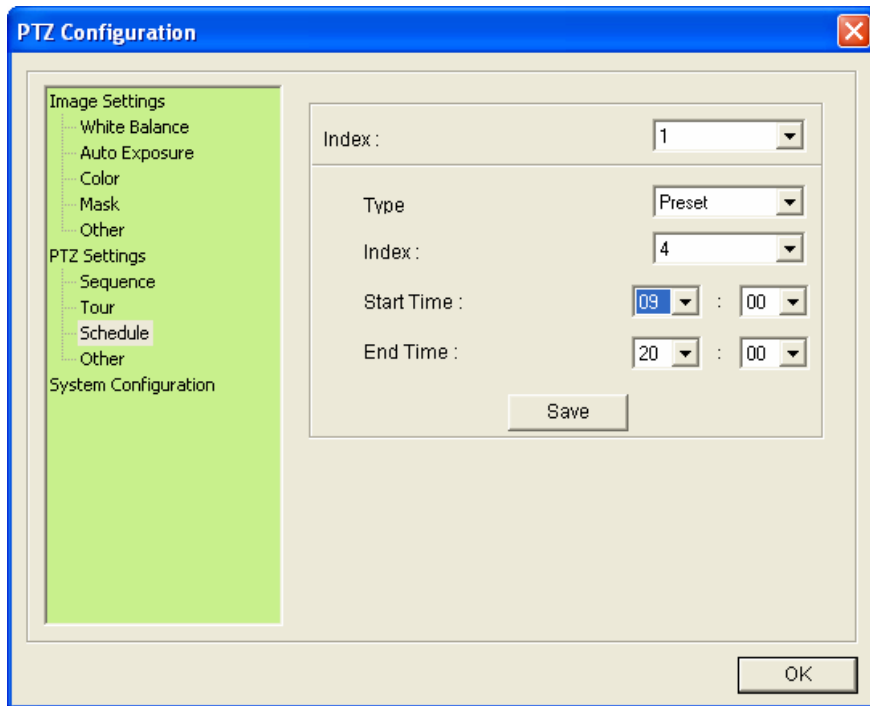

Figure 4-11

1. Select a schedule number from the **Index** drop-down list.
2. Select a movement type from the **Type** drop-down list.
3. Select a movement number from the **Index** drop-down list.
4. Select the **Start Time** and the **End Time** using the drop-down lists.
5. To create a new schedule, select a different **Index** number and repeat Steps 2 to 4.
6. Click **Save** to save the settings.

4.11 PTZ Settings– Other

This page contains speed and duration settings of Auto Pan and PT.

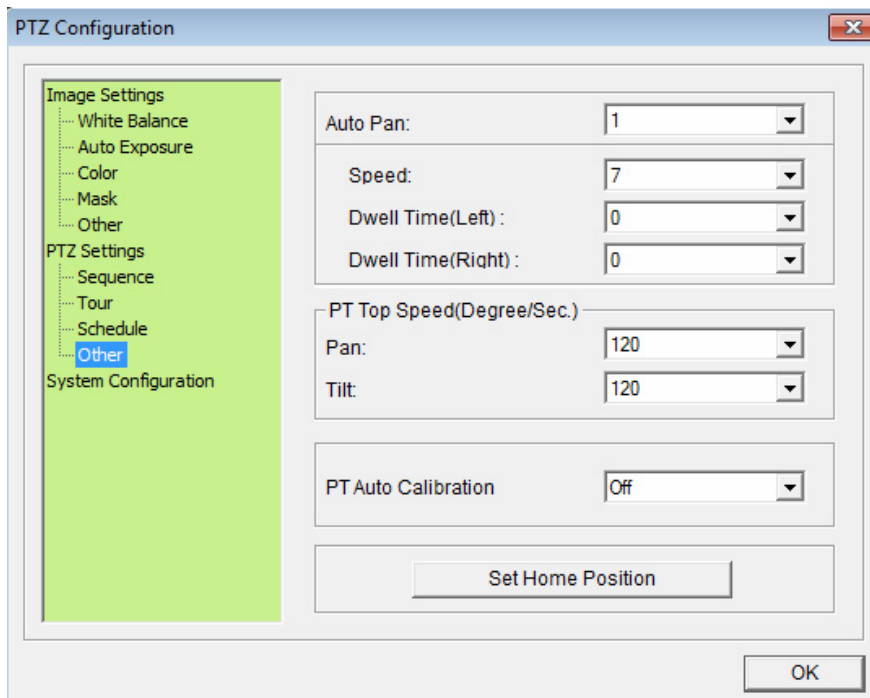

Figure 4-12

- **Auto Pan:** An Auto Pan is a pan movement of the dome view between two user-defined positions. For setup steps, see *4.3 Auto Pan Mode Settings*.
 - ⊙ **Speed:** Select the panning speed. The greater value indicates faster speed.
 - ⊙ **Dwell Time (Left):** Select the duration that the dome stays at the left point.
 - ⊙ **Dwell Time (Right):** Select the duration that the dome stays at the right point.
- **PT Top Speed:** The maximum speed for Pan and Tilt movements. Use the drop-down lists for **Pan** and **Tilt** and select a speed (degrees/second).
- **PT Auto Calibration:** Automatically calibrates the camera when it detects any inaccuracy. This function is disabled by default. For manual calibration, see *Self test* setting, *4.12 System Configuration*.
- **Set Home Position:** First adjust the dome view to a desired position and click this button to set it as your Home Position.

4.12 System Configuration

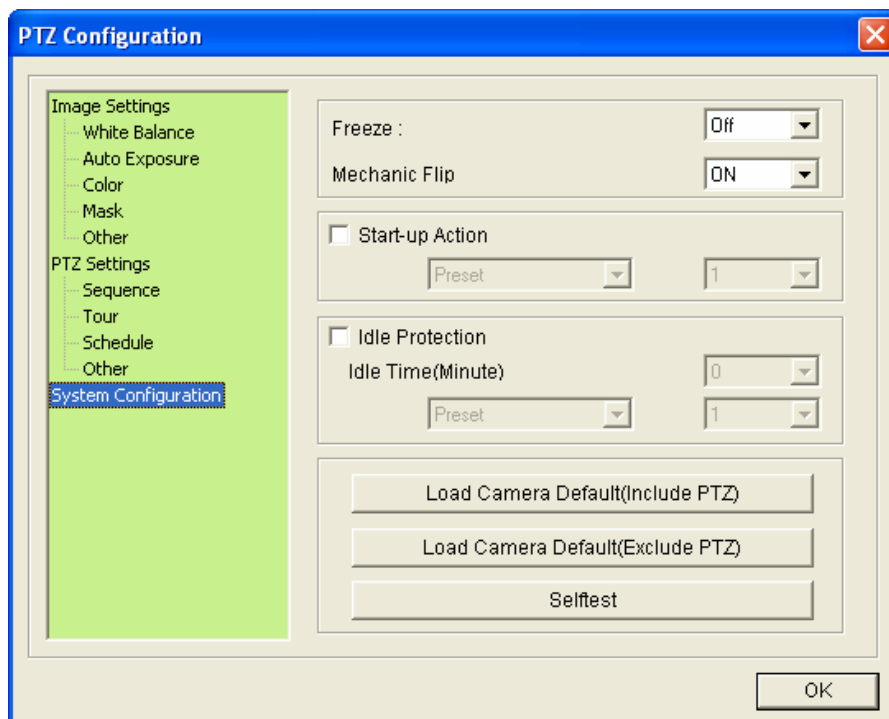

Figure 4-13

- **Freeze:** Skip showing camera images while traveling from one preset to another. This function is disabled by default.
- **Mechanic Flip:** The dome view rotates 180° when it is tilted to the maximum angle (vertically 0° or 90°) and is thus able to track objects continuously.
- **Start-Up Action:** Defines the dome view movement when the camera reboots.
- **PTZ Idle Protection:** When the dome idles for a period of time, the user can select a movement mode to activate automatic monitoring of the surveillance site. After the idle time, the selected movement mode will be automatically activated. To configure and enable this function, follow these steps:
 1. Select **Idle Protection** to start setting.
 2. Use the **Idle Time (Minute)** drop-down list to select the time length allowed for the dome to remain stationary. The time length can be set from 0 to 120 minutes.
 3. Use the drop-down list to select the desired movement mode. The modes include:
 - ⊙ **Preset:** When the Delay Time is up, the dome will automatically move to the chosen Preset point. To configure a Preset, see *4.1 Preset Settings*.
 - ⊙ **Sequence:** When the Delay Time is up, the dome will automatically perform the selected Sequence number. To configure a Sequence, see *4.4 PTZ Settings-Sequence Settings*.

- ⊙ **Auto Pan:** When the Delay Time is up, the dome will automatically perform the selected Auto Pan number. To configure an Auto Pan, see *4.3 Auto Pan Settings*.
- ⊙ **Cruise:** When the Delay Time is up, the dome will automatically perform the selected Cruise number. To configure a Cruise, see *4.2 Cruise Settings*.
- ⊙ **Tour:** When the Delay Time is up, the dome will automatically perform the selected Tour number. To configure a Tour, see *4.5 PTZ Settings-Tour Settings*.
- **Load Camera Default (Include PTZ):** Click the button to restore default settings to all the settings in PTZ Configuration dialog box (Figure 4-13).
- **Load Camera Default (Exclude PTZ):** Click the button to restore default settings to Image Settings and System Configuration in PTZ Configuration dialog box (Figure 4-13).
- **Self test:** Click this button to re-calibrate the GV-IP Speed Dome to maintain its accuracy.

Chapter 5 Administrator Mode

The Administrator can access and configure the GV-IP Speed Dome over the network. The configuration categories include: **Video and Motion**, **I/O Control**, **Events and Alerts**, **Monitoring**, **Recording Schedule**, **Remote ViewLog**, **Network**, and **Management**.

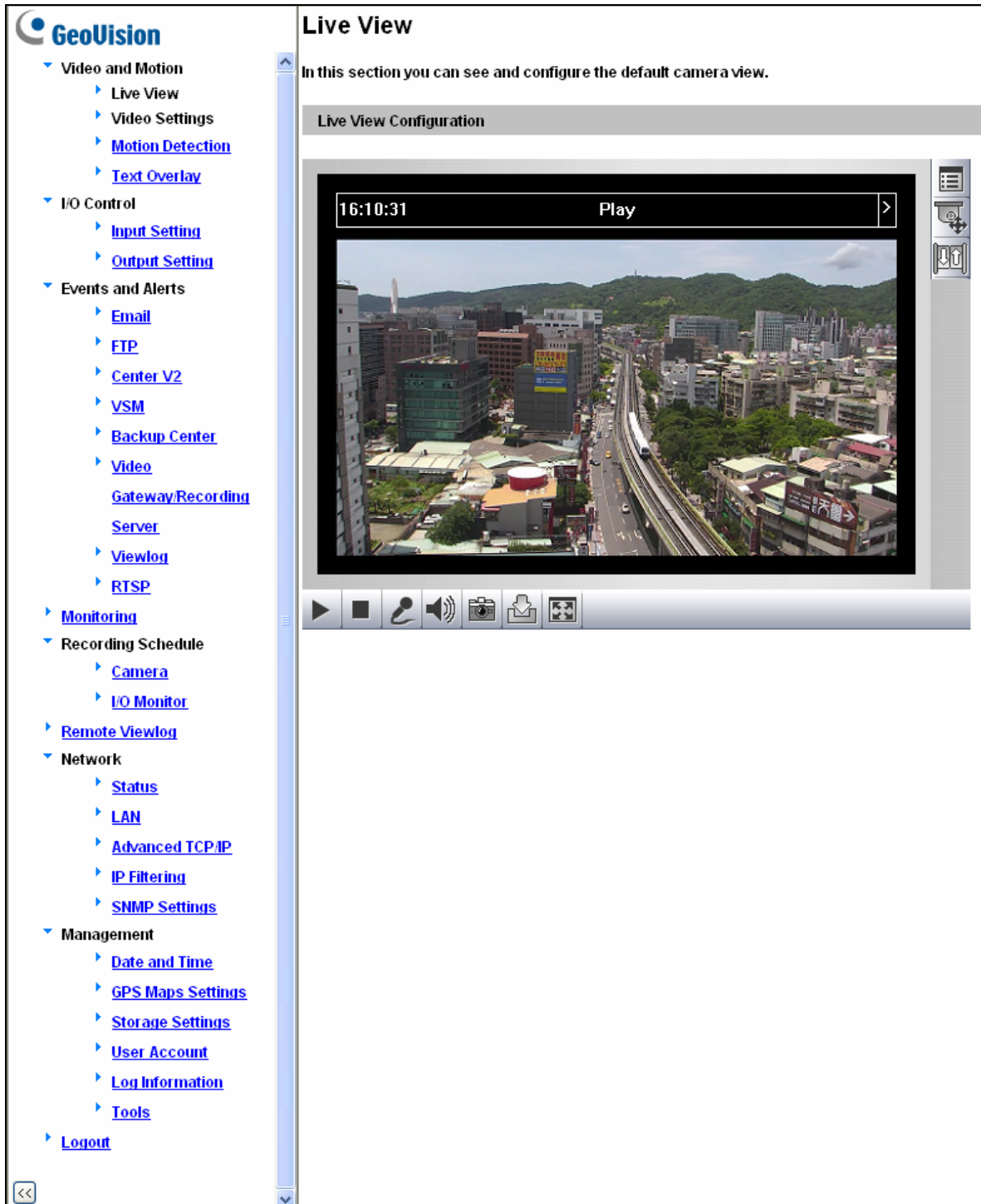

Figure 5-1

Corresponding Section for Configuration Menu

Find the topic of interest by referring to the indicated section.

5.1 Video and Motion	5.1.1 Video Settings 5.1.2 Motion Detection 5.1.3 Text Overlay
5.2 I/O Control	5.2.1 Input Settings 5.2.2 Output Settings
5.3 Events and Alerts	5.3.1 Email 5.3.2 FTP 5.3.3 Center V2 5.3.4 VSM 5.3.5 Backup Center 5.3.6 GV-Video Gateway / GV-Recording Server 5.3.7 Viewlog 5.3.8 RTSP
5.4 Monitoring	
5.5 Recording Schedule	5.5.1 Camera 5.5.2 I/O Monitor
5.6 Remote Viewlog	
5.7 Network	5.7.1 LAN 5.7.2 Advanced TCP/IP 5.7.3 IP Filter 5.7.4 SNMP Settings
5.8 Management	5.8.1 Date and Time 5.8.2 GPS Maps Settings 5.8.3 Storage Settings 5.8.4 User Account 5.8.5 Log Information 5.8.6 Tools

5.1 Video & Motion

The GV-IP Speed Dome supports dual streams, Streaming 1 and Streaming 2, which allow separate codec and resolutions settings for a single video transmission. In a bandwidth-limited network, such as mobile phone surveillance, this dual-stream feature allows you to view live video in lower resolution and codec (Streaming 2), and record in highest resolution 1920 x 1080 and codec H.264 (Streaming 1) at the same time.

Comparison between Stream 1 and Stream 2:

Video Setting Options	Stream 1	Stream 2
Video Signal Type	Different codec, resolutions and frame rates can be applied to Stream 1 and 2.	
Watermark Setting	Yes	Not configurable. Settings in Stream 1 will be automatically applied to Stream 2.
Audio In Source		
Record Settings		

5.1.1 Video Settings

Video Settings

In this section you can define compression art, broadcasting method and privacy mask.

Camera

Name

Connection template

Video Signal Type

In this section you can configure camera's video signal, also the resolution and frame per second to be transmitted through the network

Video Format

Flicker Hz 60 Hz 50 Hz

Resolution	Frame per second
<input type="text" value="1920*1080 (16:9)"/>	<input type="text" value="30"/>

Bandwidth Management

In this section you can configure the bit rate used by H.264 video stream. Using VBR (Variable Bit Rate) is an intelligent method to compensate between image quality and bandwidth control. But if you want to provide consistently the same image quality at bandwidth cost, please set to CBR (Constant Bit Rate).

VBR Quality Maximal Bit Rate Mbit

CBR Maximal Bit Rate

GOP Structure and Length

In this section you can configure the composition of the H.264 video stream (GOP structure). By using I-Frame only will increase video quality dramatically but also the bandwidth.

Group of Picture(GOP) (1 indicates to generate I-VOP only and disable motion detection)

Size

Video Slice Mode

In this section you can decide Video Slice Mode for H.264 codec, in multi-slice mode, where a single frame is cut into multiple slices and processed separately by different CPU cores.

Video Slice Mode

RecordSettings

In this section you can configure pre-alarm and post-alarm settings.

Pre-alarm recording time seconds

Post-alarm recording time seconds with hard disk installed (1~30)

Split interval minutes

Record audio

Recording With Live View

The screenshot shows a configuration menu with three sections:

- Text Overlay Settings:** A header section with the instruction "In this section you can set up Text Overlay". It contains four checkboxes: "Overlaid with camera name", "Overlaid with date stamps", "Overlaid with time stamps", and "Overlay with digital input description name". The last option is followed by four sub-checkboxes labeled "Input 1", "Input 2", "Input 3", and "Input 4".
- Watermark Setting:** A header section with the instruction "In this section you can set Watermark function.". It contains one checkbox labeled "Enable".
- Audio Settings:** A header section with a dropdown menu for "Audio Codec" currently set to "AAC".

An "Apply" button is located at the bottom left of the form.

Figure 5-2

[Name]

Rename the camera. The camera name will appear on the Live View. To display the camera name, see *3.10 Camera Name Display*.

[Connection Template]

Select the type of your network connection. Unless you select **Customized**, this option will automatically bring up the recommended video resolution, frame rate, bandwidth and GOP size.

[Video Signal Type]

Configure the codec type, signal format, resolution and frame rate. Select the codec type **H.264** or **MJPEG** for the main stream/sub stream. Choose the **Flicker Hz** value between **60 Hz** or **50 Hz**. The default is **60 Hz**. The supported resolutions are listed blow:

Streams	Ratio	Supported Resolution
Main Stream	16:9	1920 x 1080, 1280 x 720, 640 x 360, 488 x 252
Sub Stream	16:9	640 x 360, 448 x 252

[Bandwidth Management]

When using the H.264 codec, it is possible to configure the bitrate settings to control bandwidth usage.

- **VBR (Variable Bitrate):** The quality of the video stream is kept as constant as possible at the cost of a varying bitrate. The bandwidth is much more efficiently used than a comparable CBR. Set the image quality to one of the 5 standards: **Standard, Fair, Good, Great** and **Excellent**.
- **Maximal Bit Rate:** When the system bitrate exceeds the specified Maximal Bit Rate, the system will automatically lower its bitrate so as not to exceed it. Select one of the bitrates from the drop-down list or select **Auto** if you do not want to enable this function.
- **CBR (Constant Bitrate):** CBR is used to achieve a specific bitrate by varying the quality of the stream. The bitrates available for selection depend on the image resolution.

[GOP Structure and Length]

Set the maximum number of seconds between every key frame.

[Video Slice]

Corrects the display mode for the dome when it is displayed on a third-party NVR/DVR software and the live view is incomplete or broken. Select **Single Slice** or **Multi Slice** to display the live view. The default is **Auto**.

[Record Settings]

Configure recording settings for motion and I/O events, and the condition to record.

- **Pre-alarm recording time:** Activates video recording before an event occurs. Set the recording time to 1 or 2 seconds. The recording is saved in the buffer of the camera.
- **Post-alarm recording time:** Activates video recording onto the inserted memory card after an event occurs. Set the recording time from 1 to 30 seconds.
- **Split-interval:** Sets the time length between each event file from 1 to 5 minutes.
- **Record audio:** Activates audio recording when an event occurs.
- **Record to local storage when live view is accessed:** Select to continue recording to the memory card when live view is accessed through the Web interface or other software.

[Text Overlay Settings]

- **Overlaid with camera name:** Includes camera names on live and recorded videos.
- **Overlaid with date stamps:** Includes date stamps on live and recorded videos.
- **Overlaid with time stamps:** Includes time stamps on live and recorded videos.
- **Overlaid with digital input description name:** Includes the names of selected inputs on live and recorded videos.

[Watermark Setting]

Enable this option to watermark all recordings. The watermark allows you to verify whether the video has been tampered while it was recorded. See *6.4 Verifying Watermark*.

[Audio Codec] Use the drop-down list to select between G.711 and AAC options.

5.1.2 Motion Detection

Motion detection is used to generate an alarm whenever movement occurs in the dome view. You can configure up to 8 detection zones with different sensitivity values. Create at least one detection zone to enable this function.

Motion Detection

In this section you can define different region(s) for motion detection.





Camera

Sensitivity: 9

Reset

Save

Motion Detection

Ignore environmental changes

Noise Tolerance

Advanced Setting

Please advise which action(s) should be taken when motion detection is activated.

Trigger digital output relay Output 1

Figure 5-3

1. Select a sensitivity value using the slider bar. There are 10 sensitivity levels. The higher the value, the more sensitive the camera is to motion. The default sensitivity value is **9**.
2. Define a detection zone by dragging an area on the image. Click **Add** when you are prompted to confirm the setting.
3. To create several areas with different sensitivity values, repeat Steps 1 and 2.
4. Click **Save** to save the above settings.
5. Click **Reset** to clear all the selected areas.

6. For the camera to ignore environmental changes such as rain or snow, select the **Ignore environmental changes**.
7. To reduce video noise when the lighting condition changes, select **Noise Tolerance**.
8. To trigger the alarm output when motion is detected, select the **Output 1** and click the **Apply** button. To activate the output settings, you must also start **Camera** monitoring manually or by schedule. For related settings, see *5.4 Monitoring*.

5.1.3 Text Overlay

The Text Overlay allows you to overlay any text in any place on the camera view. Up to 16 text messages can be created on one camera view. The overlaid text will be saved in the recordings.



Figure 5-4

1. Select the **Enable** option.
2. Click **Set Font** to set up the font, font style and font size in a pop-up window.
3. Click any place on the image. This dialog box appears.

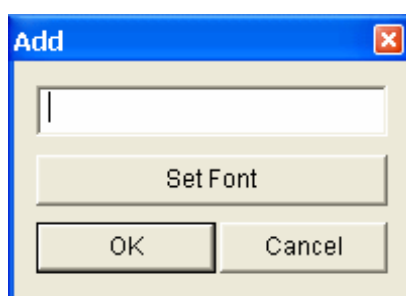

Figure 13-6

4. Type the desired text, and click **OK**. The text is overlaid on the image.
5. Drag the overlaid text to a desired place on the image.
6. Click **Set Font** to modify the font settings.
7. Click **Save** to apply the settings, or click **Load** (Undo) to revert to the last saved setting.
8. Click **Preview** to see how the text will appear on the image. Click **Close** to end the preview.

5.2 I/O Control

This section introduces how to configure the I/O devices connected to the GV-IP Speed Dome.

5.2.1 Input Settings

The GV-IP Speed Dome can connect up to 4 input devices.

Input Setting

In this section you can configure GV-IPCAM digital input port.

Digital Input 1

Enable

Name

Normal State Open Circuit (N/O) Grounded Circuit (N/C)

Latch Mode Enable

Trigger digital output relay Output 1

Send Video to CenterV2 Camera

PTZ Settings Set PTZ camera to Auto Function

Auto Function Type

Input on

Input off

Duration to set preset after input off seconds

Digital Input 2

Enable

Name

Normal State Open Circuit (N/O) Grounded Circuit (N/C)

Latch Mode Enable

Trigger digital output relay Output 1

Send Video to CenterV2 Camera

PTZ Settings Set PTZ camera to Auto Function

Auto Function Type

Input on

Digital Input 3

Enable

Name

Normal State Open Circuit (N/O) Grounded Circuit (N/C)

Latch Mode Enable

Trigger digital output relay Output 1

Send Video to CenterV2 Camera

PTZ Settings Set PTZ camera to Auto Function

Auto Function Type

Input on

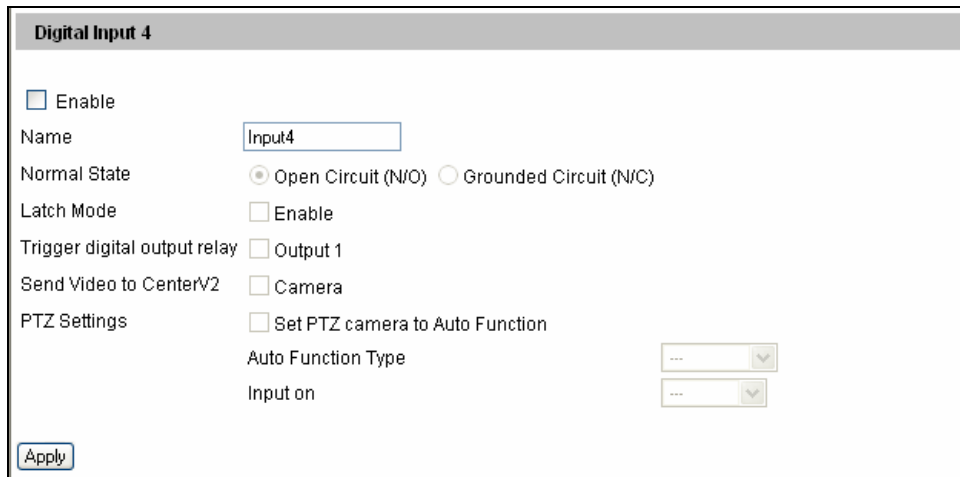

Figure 5-5

- **Name:** Edit the input name.
- **Normal State:** Set up the input state to trigger actions by selecting Open Circuit (N/O) or Grounded Circuit (N/C).
- **Latch Mode:** Enable the mode to have a momentary output alarm.
- **Trigger Digital Output Relay:** Select the output to be triggered once the input is activated.
- **Send Video to Center V2:** Select the camera to send the images to Center V2 when the input is triggered.
- **Set PTZ camera to Auto Function:** Enable this option for your GV-IP Speed Dome to perform one of the Auto Functions, including **Preset**, **Sequence**, **Auto Pan**, **Cruise** or **Tour** upon input trigger.
 - ⊙ **Input on:** Direct the GV-IP Speed Dome to the specified preset point when the input is triggered.
 - ⊙ **Input off:** Direct the GV-IP Speed Dome to the specified preset point when the triggered input is off.
 - ⊙ **Duration to set preset after input off x seconds:** Specify the amount of time the GV-IP Speed Dome stays in “Input on” preset point before moving to “Input off” preset point.

Note: The input settings only function after you start **Input** monitoring manually or by schedule. To configure the input monitoring, see [5.4 Monitoring](#).

For related PTZ settings, see *Chapter 4 PTZ Control Panel*.

5.2.2 Output Setting

The GV-IP Speed Dome can connect 1 output device.

Output Setting

In this section you can configure GV-IPCAM digital output port.

Digital Output 1 - Normal State

Enable

Name

General Mode Open Circuit (N/O) Grounded Circuit (N/C)

Toggle Mode Open Circuit (N/O) Grounded Circuit (N/C)

Pulse Mode Open Circuit (N/O) Grounded Circuit (N/C)

Trigger Pulse Mode for seconds(1~60)

Figure 5-6

Select **Enable** to start the output device. Choose the output signal that mostly suits the device you are using: N/O (Open Circuit), N/C (Grounded Circuit), N/O Toggle, N/C Toggle, N/O Pulse and N/C Pulse. For **Toggle** output type, the output will remain on once it is triggered until the next trigger. For **Pulse** output type, the output is triggered for the amount of time you specify in the Toggle Pulse Mode for x Seconds field.

5.3 Events & Alerts

For the events of motion detection or I/O trigger, the Administrator can set up two triggered actions:

1. Send a captured still image by e-mail or FTP.
2. Notify Center Monitoring Stations such as Center V2, VSM or GV-GIS, by video or text alerts.

To have above triggered actions, you must also set the following features:

- Motion Detection (See *5.1.2 Motion Detection*)
- Input Setting (See *5.2.1 Input Settings*)
- For e-mail and FTP alerts, it is required to start monitoring (See *5.4 Monitoring*).

5.3.1 E-mail

After a trigger event, the GV-IP Speed Dome can send an e-mail to a remote user containing a captured image.

Important: To send e-mail alert upon motion, be sure to set up the detection area on the Motion Detection page. For details, see *5.1.2 Motion Detection*.

Email

In this section you can configure mailserver (SMTP) to handle events, videos, and error messages.

Primary mail server

Enable

Server URL/IP Address

Server Port

From email address

Send to (Please use ";" to separate recipient's address)

Alerts Interval time in minute (0 to 60)

Need authentication to login

User Name

Password

This server requires a secure connection (SSL)

Email - Alarm Settings

Rec Error

HD Full

Motion Detection

Digital Input Select all Input1 Input2 Input3 Input4

Figure 5-7

To enable the e-mail functions:

1. Select **Enable** to set up e-mail notifications.
2. **Server URL/IP Address:** Type the SMTP Server's URL address or IP address.
3. **Server Port:** Type the SMTP Server's port number. Or keep the default value 25.
4. **From email address:** Type the sender's e-mail address.
5. **Send to:** Type the e-mail address(s) you want to send alerts to.
6. **Alerts interval time in minute:** Specify the interval between e-mail alerts. The interval can be between 0 and 60 minutes. The option is useful for frequent event occurrence. Any event triggers during the interval period will be ignored.

7. If the SMTP Server needs authentication, select **Need authentication to login** and type a valid **Username** and **Password** to log in the SMTP server. If the SMTP Server needs a secure connection (SSL), select **This server requires a secure connection**.
8. **Email-Alarm Settings:** Select to automatically send an e-mail alert when there is a recording error, when the hard drive is full, when motion is detected, and/or the input is triggered.
9. Click **Apply**.
10. In the left menu, select **Monitoring** and click the **Start** button to start monitoring.

For related settings to e-mail alerts, see *5.1.2 Motion Detection*, *5.2.1 Input Settings* and *5.4 Monitoring*.

5.3.2 FTP

You can also send the captured image to a remote FTP server for alerts.

Important: To send FTP alert upon motions, be sure to set up the detection area on the Motion Detection page. For details, see [5.1.2 Motion Detection](#).

FTP Client and Server Setting

In this section you can configure a ftp server (File Transfer Protocol) to handle events, videos, and error messages.

Upload to a FTP server

Enable

Server URL/IP Address

Server Port

User Name

Password

Remote Directory

Alerts Interval time in minute (0 to 60)

FTP - Alarm Settings

Motion Detection

Continuously send images upon trigger events(Motion)

Digital Input Select all

Input1 Input2 Input3 Input4

Continuously send images upon trigger events (Input)

Act as FTP server

In this section you can enable/disable GV-IPCAM internal ftp server for file transfer.

Enable ftp access to GV-IPCAM

Use alternative Port

Figure 5-8

[Upload to an FTP Server]

1. Select **Enable** to set up the FTP function.
2. **Server URL/IP Address:** Type the URL address or IP address of the FTP Server.
3. **Server Port:** Type the port number of the FTP Server. Or keep the default value 21.
4. Type the **Username** and **Password** of the FTP Server.
5. **Remote Directory:** Type the name of the storage folder on the FTP Server.

6. **Alerts interval time in minute:** Specify the interval between FTP alerts. The interval can be between 0 and 60 minutes. The option is useful for frequent event occurrence. Any event triggers during the interval period will be ignored.
7. **FTP-Alarm Settings:** Select to automatically send a snapshot to the FTP Server upon motion detection or input trigger. Select **Continuously send images upon trigger events (Motion)** or **Continuously send images upon trigger events (input)** to upload a series of snapshots to the FTP Server upon motion detection or input trigger.
8. **Digital Input:** Select to send a snapshot to the FTP Server when the input is triggered. Select **Continuously send images upon trigger events (Input)**.

[Act as FTP Server]

1. **Enable FTP access to the GV-IP Cam:** The GV-IP Speed Dome acts as an FTP server, enabling users to download AVI files.
2. **Use alternative port:** Modify the FTP port if needed or use the default port 21
3. Click **Apply**.
4. In the left menu, select **Monitoring** and click the **Start** button to start monitoring.

To access the internal FTP server through a web browser, enter the IP address or the domain name of the camera in your browser like this: ftp://192.168.0.10

When you are prompted for Username and Password, enter the default value **123456** in both fields. Then you should find the AVI files recorded after trigger events.

To change login information of the internal FTP server, see *5.8.4 User Account*. For the related settings to send FTP alerts, see *5.1.2 Motion Detection*, *5.2.1 Input / Output Settings* and *5.4 Monitoring*.

5.3.3 Center V2

After a motion or an I/O triggered event, the central monitoring station Center V2 can be notified by live videos and text alerts. Up to two Center V2 servers can be connected. For live monitoring through Center V2, you must already have a subscriber account on each of the Center V2 server.

Important: To notify the Center V2 Server upon motions, be sure to set up the detection area Motion Detection page.

Connection1
Connection2

Center V2

In this section you can configure the connection to Center V2 and tasks to perform.

Center V2 server

Activate Link

Host name or IP Address:

Port number:

User Name:

Password:

Cease motion detection messages from Camera

Cease input trigger message from Select all Input 1 Input 2 Input 3 Input 4

Enable schedule mode

Select schedule time

Span 1 : : : Next Day

Span 2 : : : Next Day

Span 3 : : : Next Day

Weekend Saturday and Sunday Only Sunday

Connection Status

Status: Connected. Connected Time: Wed May 2 18:52:13 2012

Figure 5-9

To enable the Center V2 connection:

1. **Activate Link:** Enable the monitoring through Center V2.
2. **Host Name or IP Address:** Type the host name or IP address of Center V2.

3. **Port Number:** Match the port to **Port 2** on Center V2. Or keep the default value 5551. For details, see *8.1 Center V2*.
4. **User Name:** Type a valid user name to log in to Center V2.
5. **Password:** Type a valid password to log in to Center V2.
6. Click **Apply**. The Connection Status should display “Connected” and connected time.
7. To establish connection to the second Center V2, click the **Connection 2** tab and repeat the above steps for setup.

These options you can also find on this Center V2 settings page:

- **Cease motion detection messages from:** Stops notifying Center V2 of motion detection.
- **Cease input trigger messages from:** Stops notifying Center V2 of input trigger from selected input(s).
- **Enable schedule mode:** Starts the monitoring through Center V2 based on the schedule you set in the **Select Schedule Time** section. Refer to *5.5 Recording Schedule* for the same settings.

For related settings to activate the monitoring through Center V2, see *5.1.2 Motion Detection*, *5.2.1 Input / Output Setting*, and *8.1 Center V2*.

5.3.4 VSM

After a motion or an I/O triggered event, the central monitoring station VSM can be notified by text alerts. Up to two VSM servers can be connected. For live monitoring through VSM, you must already have a subscriber account on each of the VSM server.

Important: To notify the VSM upon motions, be sure to set up the detection area on the [Moti Detection](#) page.

Connection1
Connection2

Vital Sign Monitor Server Setting

In this section you can configure the connection to VSM Server and tasks to perform.

Vital Sign Monitor Server

Activate Link

Host name or IP Address:

Port number:

User Name:

Password:

Cease motion detection messages from Camera

Cease input trigger message from Select all Input 1 Input 2 Input 3 Input 4

Enable schedule mode

Select schedule time

Span 1 : ~ : Next Day

Span 2 : ~ : Next Day

Span 3 : ~ : Next Day

Weekend Saturday and Sunday Only Sunday

Connection Status

Status: Connected. Connected Time: Wed May 2 18:52:13 2012

Figure 5-10

To enable the VSM connection:

1. **Activate Link:** Enable the monitoring through VSM.
2. **Host Name or IP Address:** Type the host name or IP address of VSM.

3. **Port Number:** Match the port to **Port 2** on VSM. Or keep the default value 5609. For details, see *8.2 VSM*.
4. **User Name:** Type a valid user name to log into VSM.
5. **Password:** Type a valid password to log into VSM.
6. Click **Apply**. The Connection Status should display “Connected” and connected time.
7. To establish connection to the second VSM, click the **Connection 2** tab and repeat the above steps for setup.

These options you can also find on this VSM setting page:

- **Cease motion detection messages from:** Stops notifying VSM of motion detection.
- **Cease input trigger messages from:** Stops notifying VSM of input trigger from selected input(s).
- **Enable schedule mode:** Starts the monitoring through VSM based on the schedule you set in the **Select Schedule Time** section. Refer to *5.5 Recording Schedule* for the same settings.

For related settings to activate the monitoring through VSM, see *5.1.2 Motion Detection*, *5.2.1 Input / Output Settings*, and *8.2 VSM*.

5.3.5 Backup Center

The connection to the GV-Backup Center allows you to back up another copy of recordings and system log to the GV-Backup Center on an offsite location while the camera is saving these data to the memory card. The GV-Backup Center provides a PC-based storage and backup solution. For details on the GV-Backup Center, see *GV-Backup Center User's Manual*.

Backup Center

In this section you can configure the connection to Backup Center and tasks to perform

Backup Center

Activate Link

Host name or IP Address:

Port number:

User Name:

Password:

Backup Video Select all Streaming1
 Streaming2

Compact Video Select all Streaming1
 Streaming2

Resend all files

Automatic Failover Support

Host name or IP Address:

Port number:

User Name:

Password:

Enable schedule mode

Select schedule time

Span 1 ~

Span 2 ~ Next Day

Span 3 ~ Next Day

Weekend Saturday and Sunday Only Sunday

Connection Status

Status: Connected. Connected Time: Wed May 2 18:52:13 2012

Figure 5-11

To enable connection to GV-Backup Center:

1. **Activate Link:** Enable the connection to the GV-Backup Center.
2. **Host Name or IP Address:** Type the host name or IP address of the GV-Backup Center.
3. **Port Number:** Match the communication port on the GV-Backup Center. Or keep the default value 30000.
4. **User Name:** Type a valid user name to log into the GV-Backup Center.
5. **Password:** Type a valid password to log into the GV-Backup Center.
6. **Backup Video:** Select the streams to back up their recordings to the GV-Backup Center.
7. **Compact Video:** Select the streams to only back up their Key Frames to the GV-Backup Center, instead of full recordings. This option is useful to save the backup time.
8. **Resend all files:** Select this option to send all the recorded files that have received by the Backup Center again.
9. **Enable Schedule Mode:** Enable the GV-Backup Center connection on the schedule you set in the Select Schedule Time section. Refer to *5.5 Recording Schedule* for the same settings.
10. Click **Apply**. The Connection Status should display “Connected” and connected time.

If you have a failover GV-Backup Center server which provides uninterrupted backup services in case the first GV-Backup Center failed, configure the failover GV-Backup Center as below.

1. **Automatic Failover Support:** Enable the automatic connection to the failover GV-Backup Center once the connection between camera and the first GV-Backup Center is interrupted.
2. **Host Name or IP Address:** Type the host name or IP address of the failover GV-Backup Center.
3. **Port Number:** Match the communication port on the failover GV-Backup Center. Or keep the default value 30000.
4. **User Name:** Type a valid user name to log into the failover GV-Backup Center.
5. **Password:** Type a valid password to log into the failover GV-Backup Center.
6. Click **Apply**.

5.3.6 GV-Video Gateway / GV-Recording Server

The GV-IP Speed Dome can be connected with up to two GV-Video Gateway / GV-Recording Server. To send the video images to the GV-Video Gateway or GV-Recording Server, you must already have an account on each of the GV-Video Gateway / GV-Recording Server with the user name and password specified below. Follow the steps below to set up the connection.

Connection1
Connection2

Video Gateway / Recording Server

In this section you can configure the connection to Video Gateway and tasks to perform

Video Gateway server / Recording Server

Activate Link	<input checked="" type="checkbox"/>
Host name or IP Address:	<input type="text" value="192.168.4.8"/>
Port number:	<input type="text" value="50000"/>
User Name:	<input type="text" value="admin"/>
Password:	<input type="password" value="•••"/>
Cease motion detection messages from	<input checked="" type="checkbox"/> Camera
Cease input trigger message from	<input type="checkbox"/> Select all <input checked="" type="checkbox"/> Input 1 <input type="checkbox"/> Input 2 <input type="checkbox"/> Input 3 <input type="checkbox"/> Input 4
Stop all notifications from	<input type="checkbox"/> Select all <input checked="" type="checkbox"/> Streaming 1 <input type="checkbox"/> Streaming 2
Enable schedule mode	<input checked="" type="checkbox"/>

Select schedule time

<input type="checkbox"/> Span 1	<input type="text" value="00"/> : <input type="text" value="00"/> ~ <input type="text" value="00"/> : <input type="text" value="00"/> Next Day
<input type="checkbox"/> Span 2	<input type="text" value="00"/> : <input type="text" value="00"/> ~ <input type="text" value="00"/> : <input type="text" value="00"/> Next Day
<input type="checkbox"/> Span 3	<input type="text" value="00"/> : <input type="text" value="00"/> ~ <input type="text" value="00"/> : <input type="text" value="00"/> Next Day
<input type="checkbox"/> Weekend	<input checked="" type="radio"/> Saturday and Sunday <input type="radio"/> Only Sunday

Connection Status

Status: Disconnected

Figure 5-12

To enable connection to GV-Video Gateway / GV-Recording Server:

1. **Activate Link:** Enable the monitoring through GV-Video Gateway / GV-Recording Server.
2. **Host Name or IP Address:** Type the host name or IP address of the GV-Video Gateway / GV-Recording Server.
3. **Port Number:** Match the communication port specified on GV-Video Gateway / GV-Recording Server. Or keep the default value **50000**.
4. **User Name:** Type a valid user name to log into GV-Video Gateway / GV-Recording Server.
5. **Password:** Type a valid password to log into GV-Video Gateway / GV-Recording Server.
6. Click **Apply**. The Connection Status should display “Connected” and connected time.
7. To establish connection to the second GV-Video Gateway / GV-Recording Server, click the **Connection 2** tab and repeat the above steps for setup.

You can also find on this GV-Video Gateway / GV-Recording Server settings page:

- **Enable schedule mode:** Starts the monitoring through GV-Video Gateway / GV-Recording Server based on the schedule you set in the **Select Schedule Time** section. Refer to *5.5 Recording Schedule* for the same settings.

Note: The three functions, **Cease motion detection messages from**, **Cease input trigger message from** and **Stop all notifications from**, are not functional.

5.3.7 ViewLog Server

The ViewLog Server is designed for remote playback function. This server allows you to remotely access the recorded files saved at the GV-IP Speed Dome and play back video with the ViewLog player.

Select **Enable** to activate the built-in server. Keep the default port **5552** or modify it if necessary. For details on the remote playback, see *6.2.2 Playback over Network*.

Viewlog Server Settings

In this section you can configure the connection to Viewlog Server and tasks to perform.

Viewlog Server

Enable

Port number:

Figure 5-13

5.3.8 RTSP / 3GPP

The RTSP / 3GPP Server enables video and audio streaming to your 3G-enabled mobile phone.

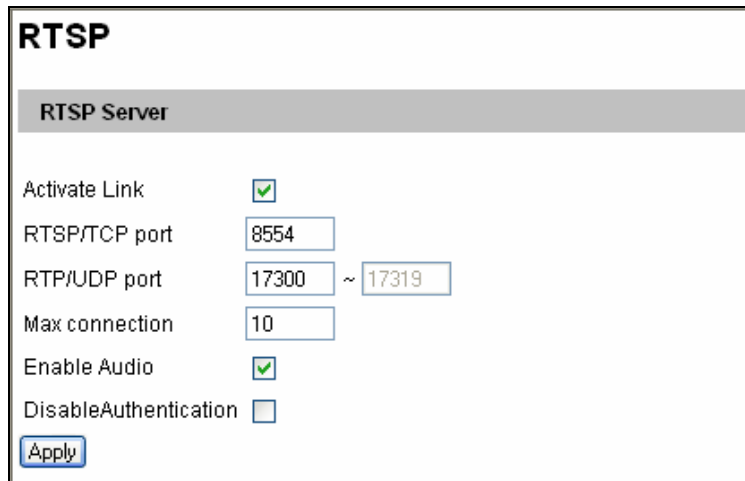

Figure 5-14

- **Activate Link:** Enable the RTSP / 3GPP service.
- **RTSP/TCP Port:** Keep the default value **8554**, or modify it if necessary.
- **RTP/UDP Port:** Keep the default range from **17300** to **17319**, or modify it if necessary. The number of ports for use is limited to 20.
- **Max Connection:** Set the maximum number of RTSP and 3GPP connections to the GV-IP Speed Dome. The maximum value is **10**.
- **Enable Audio:** This option is enabled by default. Select to enable audio streaming through RTSP.
- **Disable Authentication:** Authentication is enabled by default with which the ID and password of the GV-IP Speed Dome are required when accessing live view through the RTSP command.

For details on remote monitoring with mobile phones, see *9.4 3G Mobile Phone*.

For RTSP command, see *Appendix B RTSP Protocol Support*.

5.4 Monitoring

You can start I/O monitoring manually or by schedule.

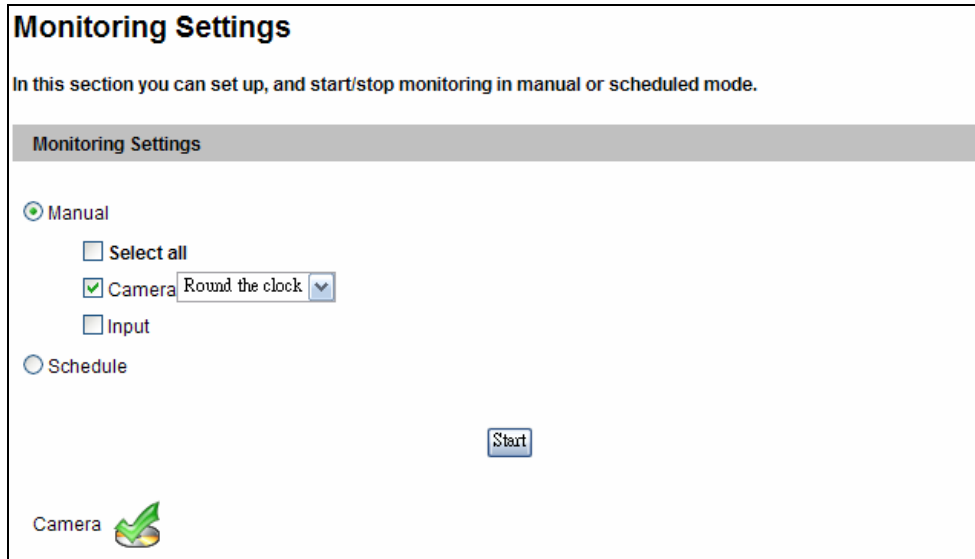



Figure 5-15

[Manual] Manually activates motion detection and I/O monitoring. Select one of the following options and then click the **Start** button.

- **Select all:** Manually starts both motion detection and I/O monitoring.
- **Camera:** Manually starts recording. Select the desired recording mode for recording.
- **Input:** Manually starts I/O monitoring. When the sensor input is triggered, its associated output will be activated for alerting, the GV-IP Speed Dome will be activated to send video to Center V2, and/or direct the GV-IP Speed Dome to a preset point. To configure the input and output settings, see *5.2.1 Input / Output Settings*.

[Schedule] The system starts motion detection and I/O monitoring according to the schedule you have set. For schedule settings, see *5.5 Recording Schedule*.

[Camera Status Icon]

 : On standby

 : Enabled for motion detection and input trigger

 : Recording is on.

5.5 Recording Schedule

The schedule settings activate recording and I/O monitoring during specific time periods each day.

5.5.1 Recording Schedule Settings

You can set up the schedule for recording.

Recording Schedule Settings

In this section you can configure schedule time.

Select schedule time

<input checked="" type="checkbox"/> Span 1	Motion	08	00	~	18	00	
<input checked="" type="checkbox"/> Span 2	Round the clock	18	00	~	06	00	Next Day
<input type="checkbox"/> Span 3	Round the clock	00	00	~	00	00	Next Day
<input type="checkbox"/> Weekend	Round the clock	<input checked="" type="radio"/> Saturday and Sunday <input type="radio"/> Only Sunday					
<input type="checkbox"/> Special Day	Round the clock	(MM/DD)					
	01.	02.	03.	04.			
	05.	06.	07.	08.			
	09.	10.	11.	12.			

Figure 5-16

- **Span 1- Span 3:** Set a different recording mode for each time span during the day. Each day can be divided into 3 time spans, shown as Span 1, Span2, and Span 3. The time span settings will apply to Monday through Sunday.
- **Weekend:** Enable this option to start monitoring all day on the weekend and select a recording mode to be used. Define whether your weekend includes **Saturday and Sunday** or **Only Sunday**.
- **Special Day:** Set the recording mode on a specified day.

5.5.2 I/O Monitoring Settings

You can set the I/O Monitoring Schedule Settings to enable I/O monitoring.

I/O Monitor Settings

In this section you can configure I/O monitor time.

Select monitor time

Span 1 00 : 00 ~ 00 : 00 Next Day
 Span 2 00 : 00 ~ 00 : 00 Next Day
 Span 3 00 : 00 ~ 00 : 00 Next Day

Weekend Saturday and Sunday Only Sunday

Special Day (MM/DD)

01.	<input type="text"/>	02.	<input type="text"/>
03.	<input type="text"/>	04.	<input type="text"/>
05.	<input type="text"/>	06.	<input type="text"/>
07.	<input type="text"/>	08.	<input type="text"/>
09.	<input type="text"/>	10.	<input type="text"/>
11.	<input type="text"/>	12.	<input type="text"/>

Figure 5-17

- **Span 1-3:** Set different time frames during the day to start I/O monitoring. Each day can be divided into 3 time frames, represented by Span 1 to Span 3. The time frame you specify is effective from Monday through Sunday.
- **Weekend:** If you want to have the whole-day monitoring for the weekend, select **Weekend**, and then define whether your weekend includes **Saturday and Sunday** or **Only Sunday**.
- **Special Day:** Enable I/O monitoring on a specified day.

5.6 Remote ViewLog

With the Remote ViewLog function, you can play back the files recorded at the GV-IP Speed Dome over TCP/IP network.

For first-time users, you need to install the Remote ViewLog program from the Software CD to the local computer. For remote access to the camera, the ViewLog Server built in the unit must be enabled. See *5.3.7 ViewLog Server*.

For details on connecting to the GV-IP Speed Dome for playback, see *6.2.2 Playback over Network*.

5.7 Network

The Network section includes some basic but important network configurations that enable the GV-IP Speed Dome to be connected to a TCP/IP network.

5.7.1 LAN Configuration

According to your network environment, select among Static IP, DHCP and PPPoE.

LAN Configuration

In this section you can configure GV-IPCAM to work inside of LAN.

LAN Configuration

Dynamic IP address Select this option to obtain IP address from a DHCP server

Static IP address Select this option to enter a Static IP address manually

IP Address:

Subnet Mask:

Router/Gateway:

Primary DNS:

Secondary DNS: (Optional)

PPPoE Select this option to establish a DSL connection

Username:

Password:

IPv6 Settings

Enable IPv6

IP Address:

Subnet Mask:

Router/Gateway:

Primary DNS:

Secondary DNS: (Optional)

Figure 5-18

[LAN Configuration]

- Dynamic IP address:** The network environment has a DHCP server which will automatically assign a dynamic IP address to the camera. Click the **Test DHCP** to see the currently assigned IP address or look up the address using GV-IP Device Utility.

- **Static IP address:** Assign a static IP or fixed IP to the camera. Type the camera's IP address, Subnet Mask, Router/Gateway, Primary DNS server and Secondary DNS server.

Parameters	Default
IP address	192.168.0.10
Subnet Mask	255.255.255.0
Router/Gateway	192.168.0.1
Primary DNS server	192.168.0.1
Secondary DNS server	192.168.0.2

- **PPPoE:** The network environment is xDSL connection. Type the Username and Password provided by ISP to establish the connection. If you use the xDSL connection with dynamic IP addresses, first use the DDNS function to obtain a domain name linking to the camera's changing IP address.

For details on Dynamic DNS Server Settings, see *5.7.2 Advanced TCP/IP*.

Note: To establish connection through a broadband modem, you may refer to this article: [ftp://geo-demo-japan.dipmap.com/Technotice/GV_IP_Devices/How to access GV-IP Camera through broadband modem.pdf](ftp://geo-demo-japan.dipmap.com/Technotice/GV_IP_Devices/How_to_access_GV-IP_Camera_through_broadband_modem.pdf)

5.7.2 Advanced TCP/IP

This section introduces the advanced TCP/IP settings, including DDNS Server, HTTP port, streaming port and UPnP.

Advanced TCP/IP

In this section you can set the advanced TCP/IP configuration

Dynamic DNS Server Settings

In this section you can configure your GV-IPCAM to obtain a domain name by using a dynamic IP.

Enable

Service Provider: Geovision DDNS Server ex: [Register Geovision DDNS Server](#)

Host Name:

User Name:

Password:

Update Time : [Refresh](#)

HTTP Port Settings

In this section you can change the default HTTP port number (80) to any port within the range 1024-65535. It is a simple method to increase system security using port mapping. You can configure HTTP connection to an alternative port.

HTTP Port:

HTTPS Settings

In this section you can change the default HTTPS port number (443) to any port within the range 1024-65535. It is a simple method to increase system security using port mapping. You can configure HTTPS connection to an alternative port.

Enable

HTTP Port:

External storage is not available. Cannot upload customized certification and private key.

Use customized certification and private key. External storage is necessary.

Certification:

Private Key:

Password:

GV-IPCAM Streaming Port Settings

In this section you can configure Streaming connection from a determine port. The default setting is 10000.

VSS Port:

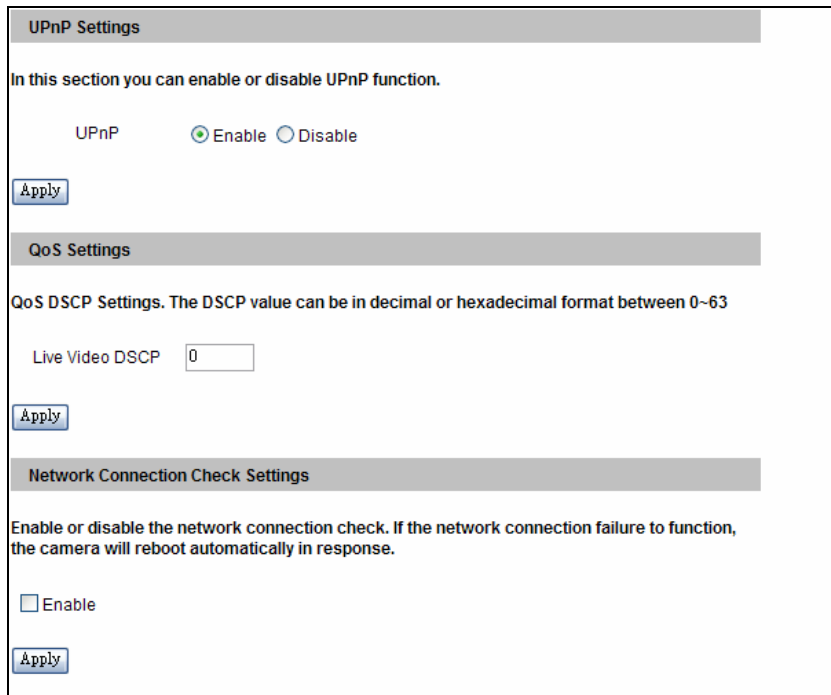

The screenshot displays three sections of a configuration page:

- UPnP Settings:** A heading followed by the text "In this section you can enable or disable UPnP function." Below this, there are radio buttons for "UPnP" with "Enable" selected and "Disable" unselected. An "Apply" button is located below the radio buttons.
- QoS Settings:** A heading followed by the text "QoS DSCP Settings. The DSCP value can be in decimal or hexadecimal format between 0-63". Below this, there is a text input field labeled "Live Video DSCP" containing the value "0". An "Apply" button is located below the input field.
- Network Connection Check Settings:** A heading followed by the text "Enable or disable the network connection check. If the network connection failure to function, the camera will reboot automatically in response." Below this, there is an unchecked checkbox labeled "Enable". An "Apply" button is located below the checkbox.

Figure 5-19

[Dynamic DNS Server Settings]

DDNS (Dynamic Domain Name System) provides a convenient way of accessing the GV-IP Speed Dome when using a dynamic IP. DDNS assigns a domain name to the GV-IP Speed Dome, so that the Administrator does not need to go through the trouble of checking if the IP address assigned by DHCP Server or ISP (in xDSL connection) has changed.

Before enabling the DDNS function, the Administrator should apply for a Host Name from the DDNS service provider's website. There are 2 providers listed in the GV-IP Speed Dome: GeoVision DDNS Server and DynDNS.org.

To enable the DDNS function:

1. **Enable:** Enable the DDNS function.
2. **Service Provider:** Select the DDNS service provider you have registered with.
3. **Host Name:** Type the host name used to link to the GV-IP Speed Dome. For the users of GeoVision DDNS Server, it is unnecessary to fill the field because the system will detect the host name automatically.
4. **User Name:** Type the user name used to enable the service from the DDNS.
5. **Password:** Type the password used to enable the service from the DDNS.
6. Click **Apply**.

[HTTP Port Settings]

The HTTP port enables connecting the GV-IP Speed Dome to the Web. For security integration, the Administrator can hide the server from the general HTTP port by changing the default HTTP port of 80 to a different port number within the range of 1024 through 65535.

[HTTPS Settings]

By enabling the Hypertext Transfer Protocol Secure (HTTPS) settings, you can access the camera through a secure protocol. You can use self-generated Certificate and Private Key or the ones verified by the SSL authority. Click **Browse** to locate the Certificate and Private Key files and type the password if the .pem files are protected by password. Click **Apply**. The Web interface will be restarted and you will need to log in again.

Note: The .pem file format is supported by Certificate and Private Key.

[IP Speed Dome Streaming Port Settings]

The VSS port enables connecting the GV-IP Speed Dome to the GV-System. The default setting is **10000**.

[UPnP Settings]

UPnP (Universal Plug & Play) is a networking architecture that provides compatibility among networking equipment, software and peripherals of the 400+ vendors that are part of the Universal Plug and Play Forum. It means that they are listed in the network devices table for the operating system (such as Windows XP) supported by this function. Enabling this function, you can connect to the GV-IP Speed Dome directly by clicking on the GV-IP Speed Dome listed in the network devices table.

[QoS Settings]

The Quality of Service (QoS) is a bandwidth control mechanism that guarantees delay-sensitive data flows such as voice and video streams, obtain a certain amount of bandwidth to keep the streaming smooth.

To apply QoS to GV-IP Speed Dome, all network routers must support QoS and QoS must be enabled on these devices. To enable the QoS on GV-IP Speed Dome, enter a Differentiated Services Code Point (DSCP) value. This value is a field in an IP packet that enables different levels of services for the network traffic. When the video stream from GV-IP Speed Dome reaches a router, the DSCP value will tell the router what service level should be applied, e.g.

the bandwidth amount. This value ranges from 0 to 63 in decimal format. The default value is 0 which means QoS is disabled. Click **Apply** to finish.

[Network Connection Check Settings]

When the network connection check is enabled, the GV-IP Speed Dome will check for Internet connection and reboots automatically when it is disconnected from the Internet.

5.7.3 IP Filter

The Administrator can set IP filtering to restrict access to the GV-IP Speed Dome.

IP Filter Setting

In this section you can allow or deny network connection listed in the table. (Filter Table support only 4 entries.)

IP Filtering

Enable IP Filtering

No.	IP Address Range in CIDR format	Action	Customize
The IP Filter has not been configured yet			

Filtered IP: ex: 192.168.1.2 or 192.168.1.0/24

Action to take: Allow ▼

Figure 5-20

To enable the IP Filter function:

1. **Enable IP Filtering:** Enable the IP Filtering function.
2. **Filtered IP:** Type the IP address you want to restrict the access.
3. **Action to take:** Select the action of **Allow** or **Deny** to be taken for the IP address(es) you have specified.
4. Click **Apply**.

5.7.4 SNMP Settings

The Simple Network Management Protocol (SNMP) allows you to monitor the status of the GV-IP Speed Dome through SNMP network management software.

SNMP Setting

In this section you can configure the SNMP settings.

SNMP Configuration

Enable SNMPv1, SNMPv2c

Read/Write community

Read only community

Enable SNMPv3

Read/Write Security name

Authentication Type

Authentication Password

Encryption Password

Read only Security name

Authentication Type

Authentication Password

Encryption Password

Figure 5-21

1. Select **Enable SNMPv1 SNMPv2c** to enable the function.
2. To enable access to **Read/Write community**, type a community string. This will serve as a password to allow read and write access to the GV-IP Speed Dome from the SNMP software.
3. To enable **Read only community**, type a community string to allow read-only access to the GV-IP Speed Dome from the SNMP software.
4. For a more secured connection, select **Enable SNMPv3** to enable SNMP version 3.
5. To enable access to **SNMPv3 Read/Write community**, type a community string.
6. Select an **Authentication Type** to use for SNMP requests.
7. Type the **Authentication Password** and **Encryption Password**. You will need to type these passwords in the SNMP software to be able to access the GV-IP Speed Dome.
8. To enable access to **SNMPv3 Read only community**, follow steps 5 – 7.
9. Click **Apply** to save the settings.

5.8 Management

The Management section includes the settings of data and time, GPS Maps and user account. Also you can view the firmware version and execute certain system operations.

5.8.1 Date and Time Settings

The date and time settings are used for date and time stamps on the image.

Date and Time Settings

In this section you can configure time and date or just synchronize with a NTP server.

Date and Time on GV-IPSpeedDome

Tue Feb 21 23:42:12 2012

Time Zone

(GMT+08:00) China,Hong Kong,Australia Western,Singapore,Taiwan,Russia ▼

Enable Daylight Saving Time

Start (MM/dd/hh/mm)

End (MM/dd/hh/mm)

Synchronized with a Network Time Server

Synchronized with Network Time Server (NTP)

Host name or IP Address:

Update period: 24 hours; Update Time: :

Synchronized with your computer or modify manually

Modify manually

Date (yyyy/mm/dd)

Time (hh:mm:ss)

Synchronized with your computer

Date and time overlay setting

Show date as ▼

(This is a format of date where yyyy stands for year in 4 digits or yy in 2 digits, mm stands for month, and dd stands for day)

Display order

Date prior to time (Ex.2007/05/21 17:00:00)

Time prior to date(Ex.17:00:00 2007/05/21)

Figure 5-22

[Date & Time on GV-IP Speed Dome] Displays the current date and time on the GV-IP Speed Dome.

[Time Zone] Sets the time zone for local settings. Select **Enable Daylight Saving Time** to automatically adjust the GV-IP Speed Dome for daylight saving time. Type the Start Time and End Time to enable the daylight saving function.

[Synchronized with a Network Time Server] By default, the GV-IP Speed Dome uses the timeserver of time.windows.com to automatically update its internal clock every 24 hours. You can change the host name or IP setting to the timeserver of interest. To change the time of automatic update, use the drop-down lists to specify the time.

[Synchronized with your computer or modify manually] Manually changes the GV-IP Speed Dome's date and time. Or, synchronize the GV-IP Speed Dome's date and time with those of the local computer.

[Date and time overlay setting] Select the display format of date and time stamps on the image. For this function to work, you must also enable the **Overlaid with date stamps** and **Overlaid with time stamps** options in Figure 5-2.

Note: When connecting to GV-System V8.5 or later, the Daylight Saving Time of GV-Speed Dome can be synchronized automatically with that of GV-System by enabling **Automatically adjust DST**. (Configure button < Camera Install < IP Camera Install)

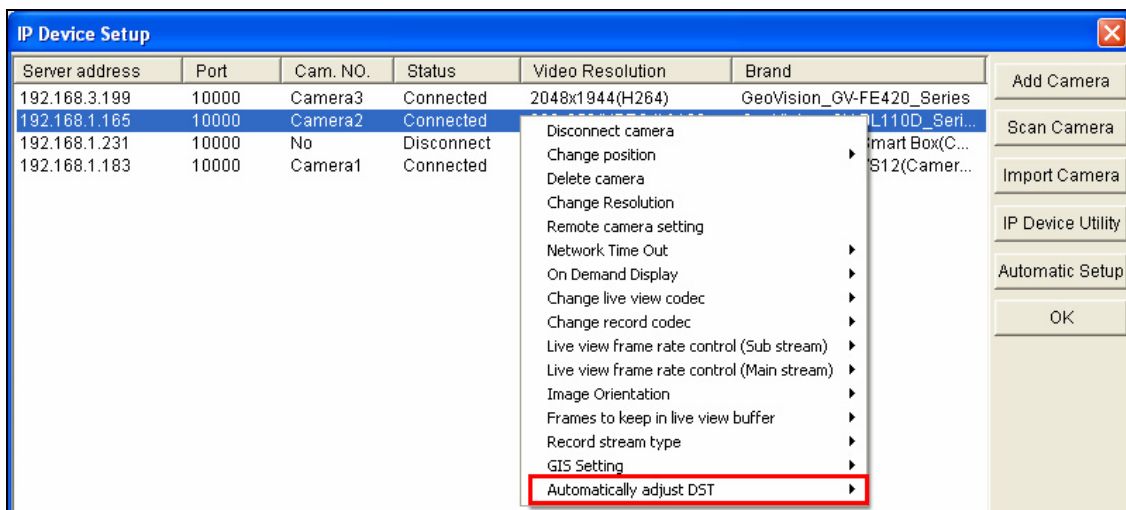

Figure 5-23

5.8.2 GPS Maps Settings

The Maps Settings allows you to see the location of your GV-IP Speed Dome on Google maps, without the need of a GPS device.

To see the location of your GV-IP Speed Dome on maps:

1. It is required to sign up for a Google Maps API key before using the Google Maps. Click **Link to the Google Maps API**.

GPS Maps

In this section you can configure the GPS Maps settings.

GPS Maps Settings

Sign Up for the Google Maps API: [Link to the Google Maps API](#)

Google Map API Key

Default Longitude (Ex.121.565=N121.565. -10.25=S10.25)

Default Latitude (Ex.25.081=E25.081. -10.25=W10.25)

Location Name

Figure 5-24

2. Enter the registered Maps API Key, the longitude and latitude of your GV-IP Speed Dome location, and location name. Click **Apply** to enable this function.
3. Open the control panel of the Live View window.

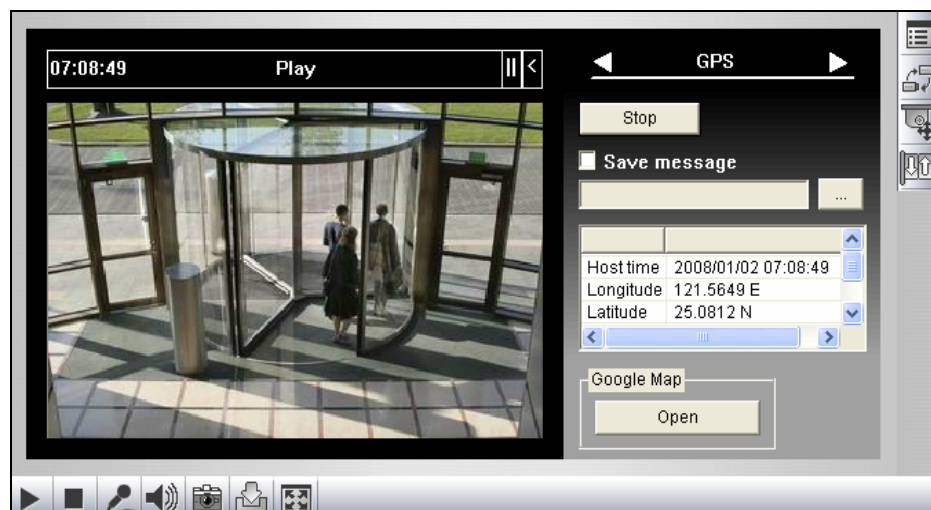

Figure 5-25

- Click **Open**. A warning message appears.

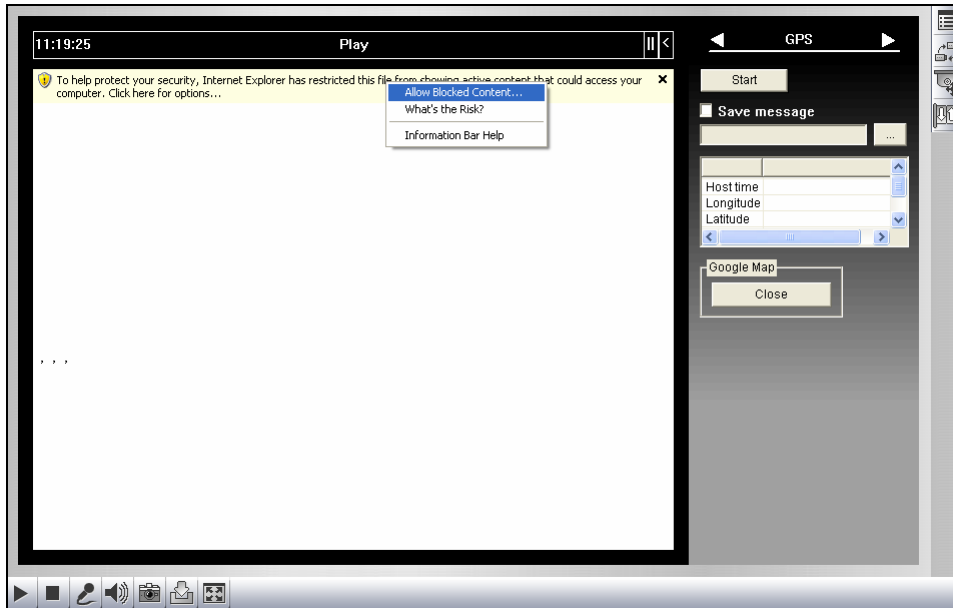

Figure 5-26

- Right-click the warning message and select **Allow Blocked Content**. The map will be displayed. The 📍 icon indicates the location of your GV-IP Speed Dome. In the upper right corner you have options to view different map formats, such as Satellite and Hybrid.



Figure 5-27

5.8.3 Storage Settings

Based on Linux ext3 file system, the GV-IP Speed Dome supports memory cards for video and audio recordings. You need to format the memory card by using the following Storage Settings. After being formatted, the memory card will be ready to use by Linux OS of the camera.

Storage Settings

In this section you can configure the disk storage to archive videos and events.

Storage Settings

Enable recycling
 Stop recording or recycle disk when free space of disk is smaller than

Keep days (1-255)

Enable debug message to the storage.

Disk Information

Disk No.	Total Size	Used Size	Free space	Utilization	Remove	Format
No HDD connected						

Partition Information

Disk No.	Partition No.	Total Size	Used Size	Free space	Utilization	Format
No HDD connected						

(Unit: Gigabyte)

Figure 5-28

[Storage Settings]

If the **Enable recycling** option is selected, when the space of the storage device is lower than the specified space, the system will either write the data to another device or overwrite the oldest recorded files.

If the **Enable recycling** option is not selected, the system will stop recording when the specified space is reached.

- **Keep days (1-255):** Specify the number of days to keep the files from 1 day to 255 days. When both **Keep days** and **Enable recycling** are selected, the system applies whichever condition comes first. For example, if the specified smallest amount of storage space comes earlier than the designated keep days, then recycle is applied first.
- **Enable debug message to the storage:** Select this option to store the debug messages (log information) to the inserted device.

[Disk Information]

This section shows the details of the attached storage devices.

[Partition Information]

This section shows the partition details of the attached storage devices.

To add a memory card:

1. Insert the memory card to the camera.
2. Click the **Format** button.
3. After the format is complete, the partition information will display. The maximum space for one partition is 200 GB.

To remove a memory card:

1. Click the **Remove** button.
2. When you are prompted to confirm the action, click **Yes**. The page will be refreshed and the partition information will be cleaned.
3. Remove the memory card from the camera.

Note:

1. If **Enable Recycle** is selected, the available space of the storage device must be higher than the space you specified at the **Stop recording or recycle disk when free space of disk is smaller than x** option. Otherwise no video will be recorded.
 2. The recording data may be lost if you remove the storage device during recording.
 3. If you do not remove the storage device properly, the data cannot be read in another computer. In this case, re-plug the storage device back to the camera. The system will repair the data automatically. When the system is repairing the data, the **Remove** field will display "Repairing".
-

5.8.4 User Account

You can change the login name and password of Administrator, Guest and FTP Server User.

- The default Administrator login name and password are **admin**.
- The default Guest login name and password are **guest**. To allow a Guest user log in without entering the username and password, select **Disable authentication for guest account**.
- To remain logged in after reboot, select **Disable auto logout after reboot**.
- The default FTP Server login name and password are **ftpuser**.

User Account

In this section you can change the administrator account and password

Administrator Account

Username:

Old Password:

New Password:

Confirm Password:

Guest User Account

Username:

Old Password:

New Password:

Confirm Password:

Advanced Setting

Disable authentication for guest account

Disable auto logout after reboot

FTP Server User Account

Username:

Old Password:

New Password:

Confirm Password:

Figure 5-29

Note: You can also access this User Account interface simply by executing a CGI command.
See *Appendix A*.

5.8.5 Log Information

The log contains dump data that is used by service personnel for analyzing problems.

Log Information

In this section you can see all system activities.

Startup time log

In this section you can see latest booting time of system.

```
[0] Thu Jun 11 16:29:34 2009
[3] Thu Jun 11 16:31:21 2009
[2] Thu Jun 11 16:35:54 2009
```

System Log

In this section you can see all system activities.

```
Jan 1 00:00:07 FIE8180 syslog.info syslogd started: BusyBox v1.1.3
Jan 1 00:00:08 FIE8180 daemon.info linuxrc: Starting pid 49,
console /dev/console: '/sbin/getty'
Jan 1 00:00:07 FIE8180 user.debug kernel: Init PCI bridge controller
Jan 1 00:00:08 FIE8180 user.info kernel: PCI: bus0: Fast back to
back transfers disabled
Jan 1 00:00:08 FIE8180 user.err kernel: Not Support Slot 0
Jan 1 00:00:08 FIE8180 user.debug kernel: Calling initcall
0xc0014a78: init_bio+0x0/0x150()
Jan 1 00:00:08 FIE8180 user.debug kernel: Calling initcall
0xc001a0a4: fbmem_init+0x0/0xa4()
Jan 1 00:00:08 FIE8180 user.debug kernel: Calling initcall
0xc001a8d0: misc_init+0x0/0x9c()
Jan 1 00:00:08 FIE8180 user.debug kernel: Calling initcall
0xc001bfa0: genhd_device_init+0x0/0x44()
Jan 1 00:00:08 FIE8180 user.debug kernel: Calling initcall
0xc001d3f8: init_scsi+0x0/0xb8()
Jan 1 00:00:08 FIE8180 user.notice kernel: SCSI subsystem
initialized
Jan 1 00:00:08 FIE8180 user.debug kernel: Calling initcall
0xc001dbf8: input_init+0x0/0x174()
Jan 1 00:00:08 FIE8180 user.debug kernel: Calling initcall
0xc001e740: proto_init+0x0/0x48()
Jan 1 00:00:08 FIE8180 user.debug kernel: Calling initcall
```

Figure 5-30

5.8.6 Tools

This section allows you to execute certain system operations and view the firmware version.

Additional Tools

In this section you can set the additional tools

Host Settings

In this section you can determine a hostname and camera name for identification.

Host Name

Auto Reboot Setup

In this section you can set the system's auto reboot time.

Enable

Day Interval days

RebootTime :

Repair Recording Database

Click Apply to repair the database when you cannot play back recordings.

Repairing Status

Firmware Update

In this section you can see GV-IPCAM firmware version.

IP Speed Dome Model Info

IP Speed Dome Model Info

System Settings

Restore to factory default settings

Internal Temperature

Internal Temperature Normal Range: 0°C ~ 95°C "(32°F ~ 203°F)"

Current chipset temperature inside camera is °C / °F

Reboot

Do you wish to reboot now?

Figure 5-31

[Host Settings] Enter a descriptive name for the GV-IP Speed Dome.

[Auto Reboot Setup] Select **Enable** to activate automatic reboot and specify the time for reboot in the sub fields below.

- **Day Interval:** Type the day interval between the reboots.
- **Reboot Time:** Use the drop-down list to specify the time for automatic reboot.

[Repair Record Database] Click **Apply** to repair the database when errors occur while playing back the recordings with the Remote ViewLog player. Problems can occur when there are errors in firmware or damages to the SD card.

[Database Status] Displays the repairing status of database.

[Firmware Update] This field displays the firmware version of the GV-IP Speed Dome.

[IP Speed Dome Model Information] This field displays the model name of the GV-IP Speed Dome.

[System Settings] Click the **Load Default** button to restore all the settings of GV-IP Speed Dome (except settings in the PTZ Configuration dialog box) to factory default settings.

Note: After applying the default function, you will need to configure the GV-IP Speed Dome's network setting again.

[Temperature Status] Displays the current chipset temperature inside the GV-IP Speed Dome.

[Reboot]

Clicking the **Reboot** button will make the GV-IP Speed Dome perform the software reset.

5.8.7 Language

You can change the language for the Web interface.

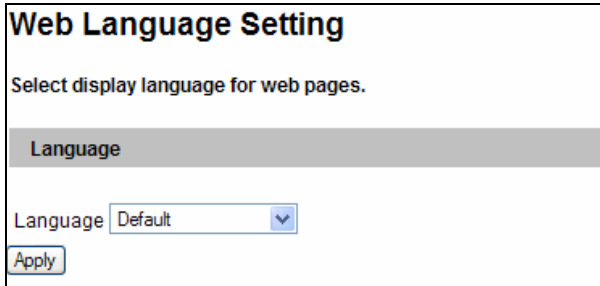

Web Language Setting

Select display language for web pages.

Language

Language

Figure 5-32

Use the Language drop-down list to select a language for the Web interface. By default, the language on the Web interface will be the same with the one used for the operating system.

Chapter 6 Recording and Playback

The GV-IP Speed Dome can record video and audio directly to the memory card. You can play back the recorded files on the GV-System or over the TCP/IP network.

Note: See **Note for Connecting to GV-System** at the beginning of the manual.

6.1 Recording

To enable the recording function:

1. Insert the memory card to the camera. See “To add a memory card”, *5.8.3 Storage Settings*.
2. If you like to set up the pre-recording, post-recording or audio recording, see *5.1.1 Video Settings*.
3. If you like to set up the schedule for video recording or I/O monitoring, see *5.5 Recording Schedule*.
4. If you like to configure the areas and sensitivity values for motion detection, see *5.1.2 Motion Detection*.
5. If you want the recording to be triggered by input device, configure the operation of input device. See *5.2.1 Input Settings*.
6. To start recording and I/O monitoring, see *5.4 Monitoring*.

The camera will start recording in case of motion detection, I/O trigger, or during the scheduled time.

6.2 Playback

You can use the following methods to play back video files recorded at the GV-IP Speed Dome:

- Playback by using the memory card by connecting it directly to the GV-System through a memory card reader
- Playback by using the Remote ViewLog function over the TCP/IP network
- Playback by using the recorded files downloaded from built-in FTP Server

6.2.1 Playback Using the Memory Card

You can play back the files recorded at the GV-IP Speed Dome by connecting the memory card to GV-System through a memory card reader. However, GV-System is run on Windows system while the files recorded at the GV-IP Speed Dome is of Linux file system. For Windows to recognize the files, you need to install **IFS Driver**.

1. Insert the Software CD, select **IFS Drives** and follow the onscreen instructions for installation.
2. Run **IFS Drives** from Control Panel, and assign the drive name(s) to each available partition in the storage device.

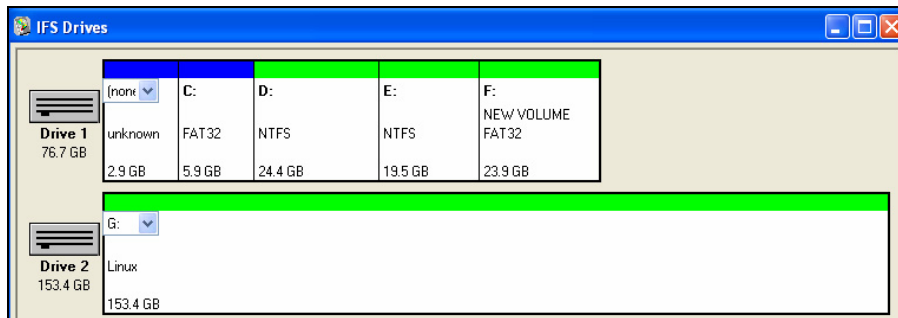



Figure 6-1

3. Run **ViewLog**.

4. Click the **Advanced** button , select **Reload Database** and click **Video Server/Compact DVR**. This dialog box appears.

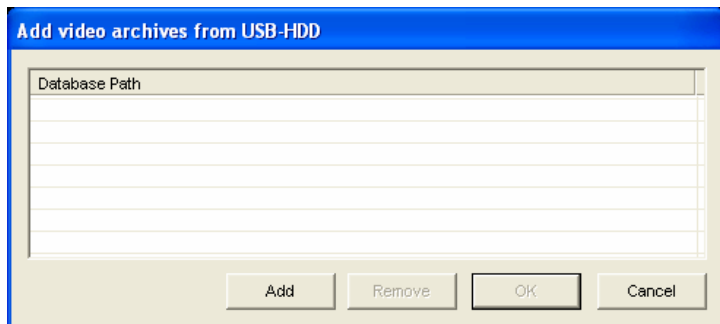

Figure 6-2

5. Click **Add** to assign the hard drive.
6. Click **OK** to load the data to the ViewLog for playback.

Note: IFS Driver supports Windows NT / 2000 / XP / Windows 7. For Windows 7, refer to ftp://geo-demo-japan.dipmap.com/Technotice/GV_IP_Devices/Run_IFS_Driver_Win7.pdf to see how to configure the settings.

6.2.2 Playback over Network

You can also play back the files recorded at the GV-IP Speed Dome over TCP/IP network using the Remote ViewLog function.

1. The camera needs to allow the remote access with **ViewLog Server** activated. See *5.3.7 ViewLog Server*.
2. For the first-time user, run the **Remote ViewLog** program from the Software CD. Next time whenever you like to use this remote playback function, access this option from the camera's Web interface.
3. When the Remote ViewLog player is open, you will be prompted to select Remote ViewLog Service or Remote Storage System. Select **Remote ViewLog Service**.
4. When this dialog box appears, type the camera's IP address, login ID and password. Keep the default port **5552** or modify it if necessary.

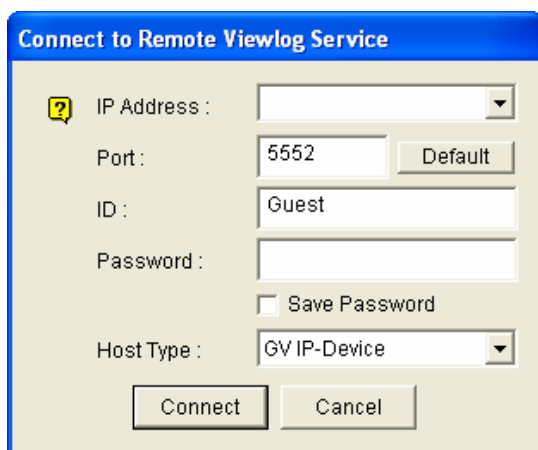

Figure 6-3

5. In the Host Type field, select **GV-IP Device**.
6. Click **Connect** to access the files of the camera for playback.

6.2.3 Access to the Recorded Files through FTP Server

You can download the recorded files saved on the memory card using the built-in FTP Server. You can play back the downloaded files of AVI format on Media Player. For details to download files, see [Act as FTP Server], 5.3.2 *FTP*.

Note: To play back videos, ensure you have installed Geovision codec on the computer. The codec is available on the Software CD. If you have installed the Remote Playback player on the computer, it is not required to install the codec.

6.2.4 Playback of Daylight Saving Time Events

On GV-System, you can retrieve and play back the events recorded during the Daylight Saving Time (DST) period from the GV-IP Speed Dome. You can also connect the memory card to GV-System for playback.

The following instructions describe how to retrieve the recorded files from the GV-IP Speed Dome over network. To play back using the memory card, first follow the instructions in 6.2.1 *Playback Using the Memory Card* to load the recorded files to ViewLog, and then follow Steps 4-5 below to play back DST events.

1. The camera must allow the remote access with **ViewLog Server** activated. See 5.3.7 *ViewLog Server*.
2. To remotely connect to the GV-IP Speed Dome from GV-System, click the **Tools** button and select **Remote ViewLog Service**. The Connect to Remote ViewLog Service dialog box appears.
3. Enter the connection information of the camera, and click **Connect**. Once the connection is established, the video events will be displayed on the Video Event list.
4. On the Date Tree, select the date of Daylight Saving Time. A separate DST subfolder will be displayed as illustrated below.

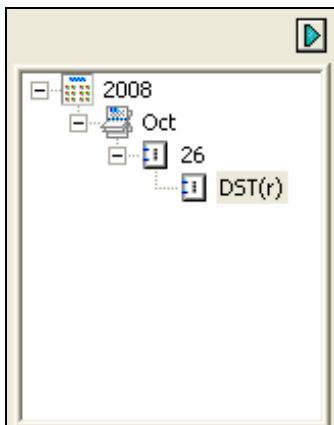

Figure 6-4

5. On the Video Event list, select desired events, and click the **Play** button to start.

Note:

1. The playback function is only compatible with the GV-System of version 8.3 and later.
 2. The AVI file recorded during the DST period is named with the prefix “GvDST”, e.g. GvDST20081022xxxxxxxxx.avi, to differentiate from the regular AVI file named with the prefix “Event”, e.g. Event20081022xxxxxxxxx.avi.
-

Chapter 7 Advanced Applications

This chapter introduces more advanced applications.

7.1 Upgrading System Firmware

GeoVision periodically updates the latest firmware to the company website. You can update your GV-IP Speed Dome firmware through the Web interface or GV IP Device Utility included in the Software CD.

Important Notes before You Start

Before you start updating the firmware, please read these important notes:

1. While the firmware is being updated, the power supply must not be interrupted.

WARNING: The interruption of power supply during updating causes not only update failures but also damages to your GV-IP Speed Dome. In this case, please contact your sales representative and send your device back to GeoVision for repair.

2. Do not turn the power off within 10 minutes after the firmware has been updated.
3. If you use the IP Device Utility for firmware upgrade, the computer used to upgrade firmware must be under the same network as the GV-IP Speed Dome.
4. Stop monitoring of GV-IP Speed Dome.
5. Stop all the remote connections including Center V2, VSM, ViewLog Server and 3GPP/RTSP.
6. Stop the connection to GV-System.

7.1.1 Using the Web Interface

1. In the Live View window, click the **Show System Menu** button (No. 12, Figure 3-2) and select **Remote Config**. This dialog box appears.

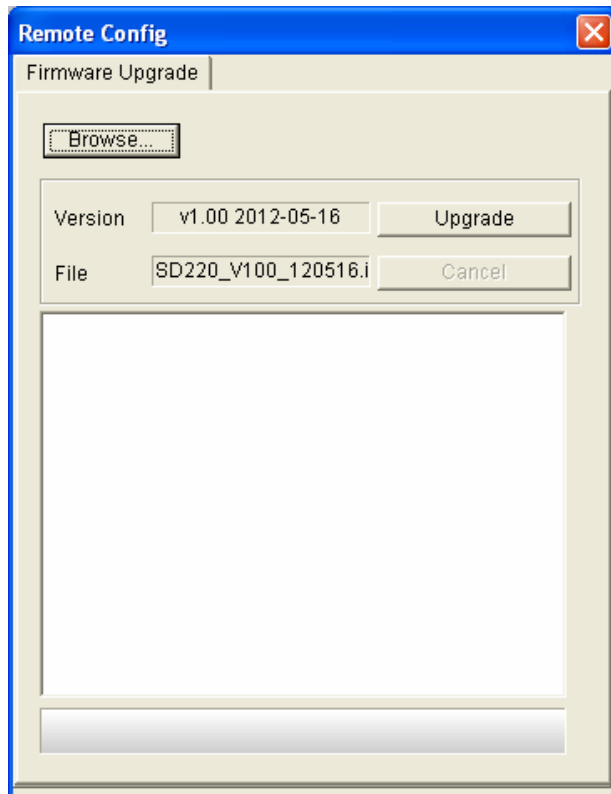

Figure 7-1

2. Click the **Browser** button to locate the firmware file (.img) saved at your local computer.
3. Click the **Upgrade** button to start upgrading.

7.1.2 Using the GV IP Device Utility

The IP Device Utility provides a direct way to upgrade the firmware to multiple GV-IP Speed Domes. Note the computer used to upgrade firmware must be under the network of the GV-IP Speed Dome.

1. Insert the Software CD, select **IP Device Utility**, and follow the onscreen instructions to install the program.
2. Double-click the **IP Device Utility** icon created on your desktop. This dialog box appears.

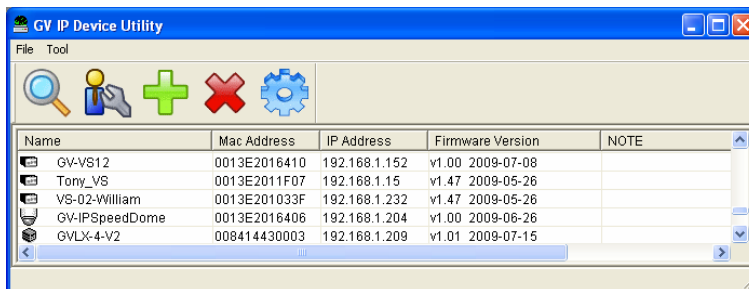

Figure 7-2

3. Click the **Search** button to locate the available GV-IP Speed Domes on the same LAN. Or click the **New** button and assign the IP address to locate a GV-IP Speed Dome on the Internet. Or highlight one GV-IP Speed Dome in the list and click the **Delete** button to remove it.
4. Double-click one GV-IP Speed Dome in the list. This dialog box appears.

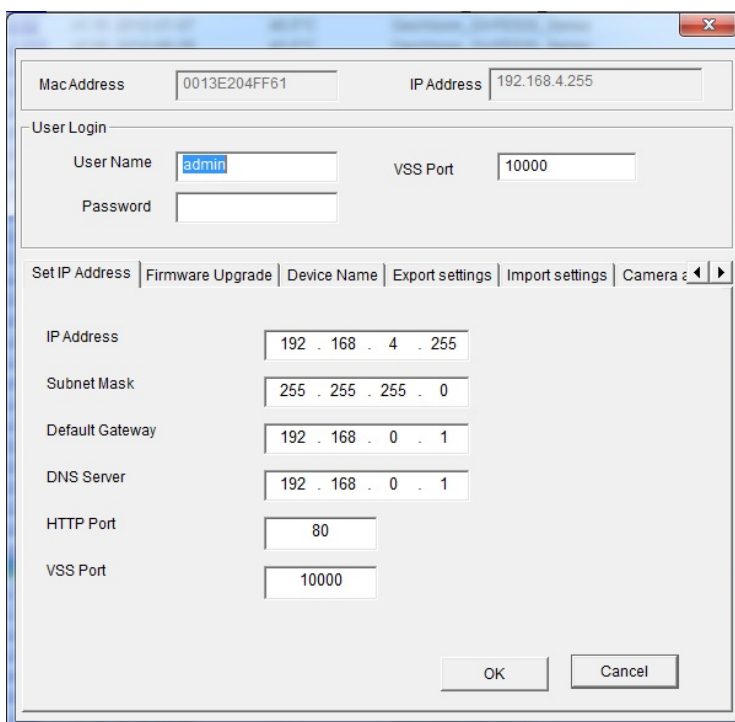

Figure 7-3

5. Click the **Firmware Upgrade** tab. This dialog box appears.

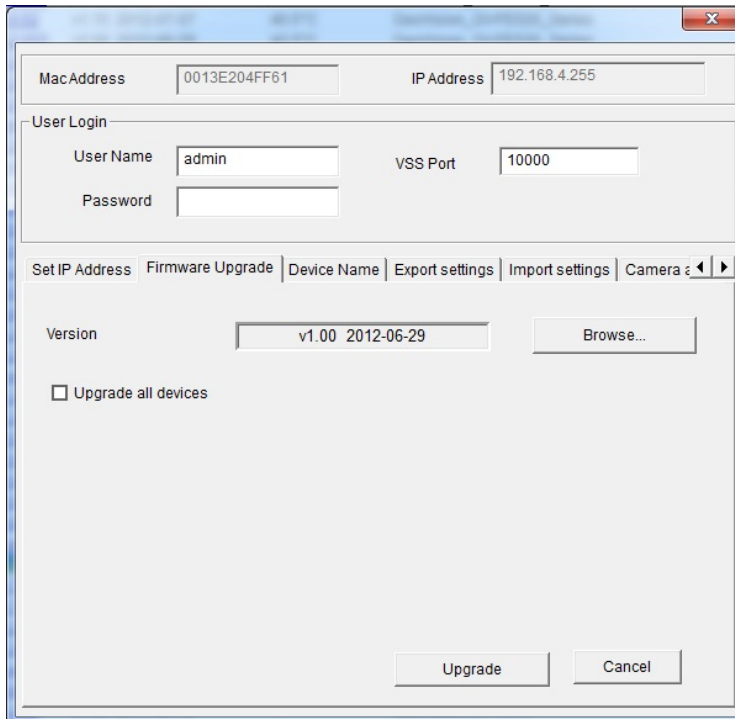

Figure 7-4

5. Click the **Browse** button to locate the firmware file (.img) saved at your local computer.
6. If you like to upgrade all the GV-IP Speed Domes in the list, check **Upgrade all devices**.
7. Type **Password**, and click **Upgrade** to start the upgrade.

7.2 Backing Up and Restoring Settings

With the IP Device Utility included on the Software CD, you can back up the configurations in the GV-IP Speed Dome, and restore the backup data to the current unit or import it to another unit.

Note: The settings for PTZ movements (Preset, Sequence, Cruise, Auto Pan and Tour) of the GV-IP Speed Dome can not be exported and imported.

To back up the settings:

1. Run **IP Device Utility** and locate the desired GV-IP Speed Dome. See Steps 1-3 in 7.1.2 *Using the IP Device Utility*.
2. Double-click the GV-IP Speed Dome in the list. Figure 7-3 appears.
3. Click the **Export Settings** tab. This dialog box appears.

The screenshot shows a dialog box titled "IP Device Utility" with the following fields and controls:

- Mac Address: 0013E204FF61
- IP Address: 192.168.4.255
- User Login section:
 - User Name: admin
 - Password: [empty]
 - VSS Port: 10000
- Navigation tabs: Set IP Address | Firmware Upgrade | Device Name | **Export settings** | Import settings | Camera z ◀ ▶
- Save File Path: C:\Users\Test-PT630\Desktop\IP_192.168.4.255.dat (with a Browse... button)
- Buttons: Export settings, Cancel

Figure 7-5

4. Click the **Browse** button to assign a file path.
5. Type **Password**, and click **Export Settings** to save the backup file.

To restore the settings:

1. In Figure 7-3, click the **Import Settings** tab. This dialog box appears.

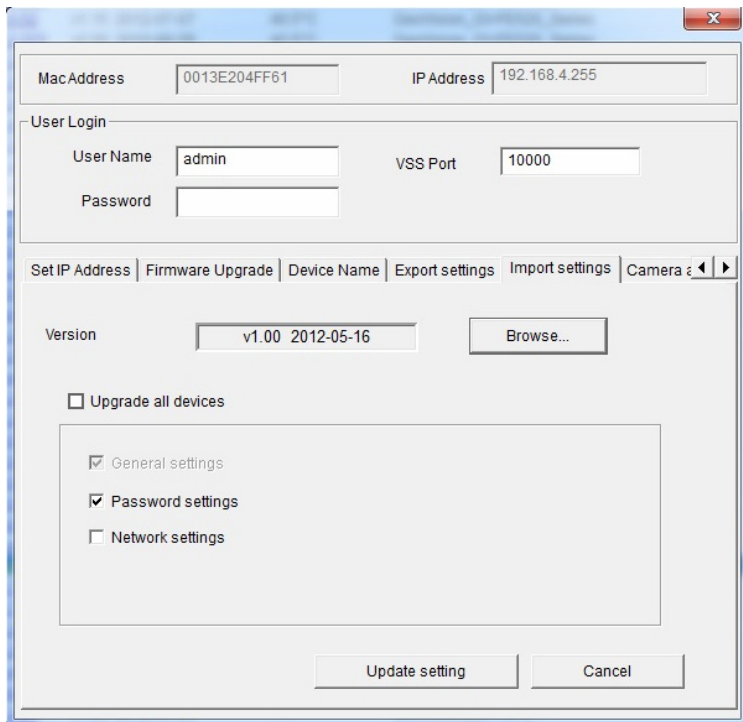

Figure 7-6

2. Click the **Browse** button to locate the backup file (.dat).
3. Select **Upgrade all devices** to import the settings into the same type of device in the same LAN. To import password settings and/or network settings, select **Password Settings** and/or **Network settings**.
4. Click the **Upgrade setting** button to start restoring.

7.3 Restoring to Factory Default Settings

The settings and default restoration of GV-IP Speed Dome are divided into two parts: system settings, which are all the settings on Web interface, excluding PTZ control panel; and PTZ configuration settings (Figure 4-3). You may choose to load all the settings, or just one part of the settings.

To restore all the settings

1. Press and hold the **Default** button (No. 1, Figure 1-3).
2. When the **status LED** (No. 2, Figure 1-3) flashes twice, release the **Default** button. This shall take about 6 seconds.
3. The default loading is completed when the status LED fades.

To restore system settings only:

On the Web interface, select **Tools** and click the **Load Default** button. The default loading will start shortly.

To restore PTZ configuration settings only:

1. Access the PTZ Configuration dialog box. For details, see *Calling Up the PTZ Control Panel* and *Accessing the PTZ settings*, Chapter 4.
2. On the PTZ Configuration dialog box (Figure 4-3), select **System Configuration**. This dialog box appears.

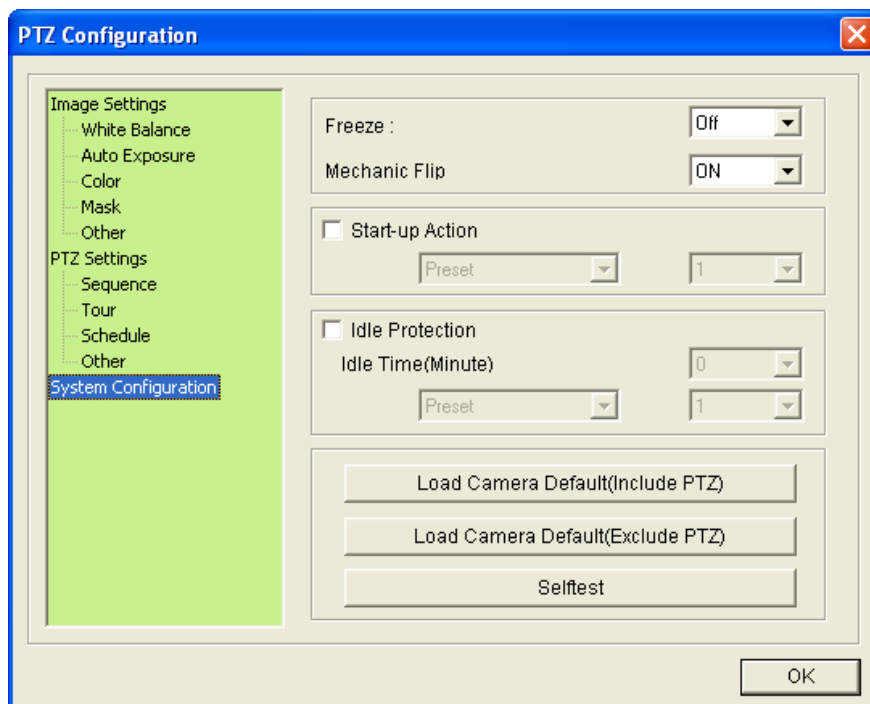

Figure 7-7

3. To restore default settings to all the settings in PTZ Configuration, click **Load Camera Default (Include PTZ)**. To restore default settings to Image Settings and System Configuration settings only, click **Load Camera Default (Exclude PTZ)**.

7.4 Verifying Watermark

The watermark is an encrypted and digital signature embedded in the video stream during the compression stage, protecting the video from the moment of creation. Watermarking ensures that an image is not edited or damaged after it is recorded. To enable the watermark function, see [Watermark Setting], 5.1.1 *Video Settings*.

The Watermark Proof is a watermark-checking program. It can verify the authenticity of the recording before you present it in court.

7.4.1 Accessing AVI Files

To verify watermark, access the recorded AVI files by one of the following methods:

1. Use the **File Save** function (No. 6, Figure 3-2) to start recording on the local computer.
2. Locate recorded files on the GV-System.

7.4.2 Running Watermark Proof

1. Install **Watermark Proof** from the Software CD. After installation, a **WMPproof** icon is created on your desktop.
2. Double-click the created icon. The Water Mark Proof window appears.
3. Click **File** from the menu bar, select **Open** and locate the recording (.avi). The selected recording is then listed on the window. Alternatively, you can drag the recording directly from the storage folder to the window.
4. If the recording is unmodified, a check mark will appear in the **Pass** column. On the contrary, if the recording is modified or does not contain watermark during recording, a check mark would appear in the **Failed** column. To review the recording, double-click the listed file on the window.

7.4.3 The Watermark Proof Window

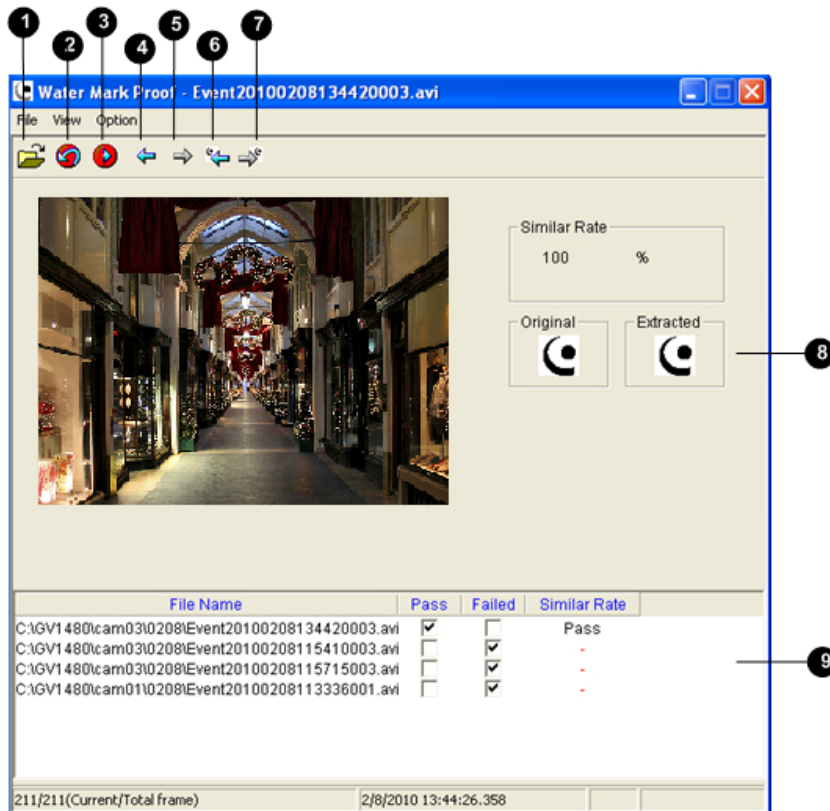

Figure 7-8

The controls in the window:

No.	Name	Description
1	Open File	Opens the recording.
2	First Frame	Goes to the first frame of the file.
3	Play	Plays the file.
4	Previous Frame	Goes to the previous frame of the file.
5	Next Frame	Goes to the next frame of the file.
6	Previous Watermarked Frame	Goes to the previous frame that contains watermark.
7	Next Watermarked Frame	Goes to the next frame that contains watermark.
8	Original vs. Extracted	The Extracted icon should be identical with the Original icon. If not, it indicates the recording has been tampered.
9	File List	Displays the proof results.

7.5 Downloading Videos from the SD Card

When connections of GV-IP Speed Dome to the GV-System are lost, recordings are automatically saved to the memory cards inserted in the GV-IP Speed Dome. To automatically synchronize and download recordings from the SD cards to a local folder, install and execute the GV-SDCardSync Utility program.

7.5.1 Installing the GV-SDCardSync Utility

1. Download the GV-SD Card Sync Utility program from http://ftp.geovision.tw/FTP/neo/Utility/GvSDCardSync_Setup.zip
2. Execute the **GV-SDCard Sync Utility** program. The main window and the Setting window appear. The Setting window pops up automatically upon first execution. Otherwise, click the **Setting** button  on the main window.

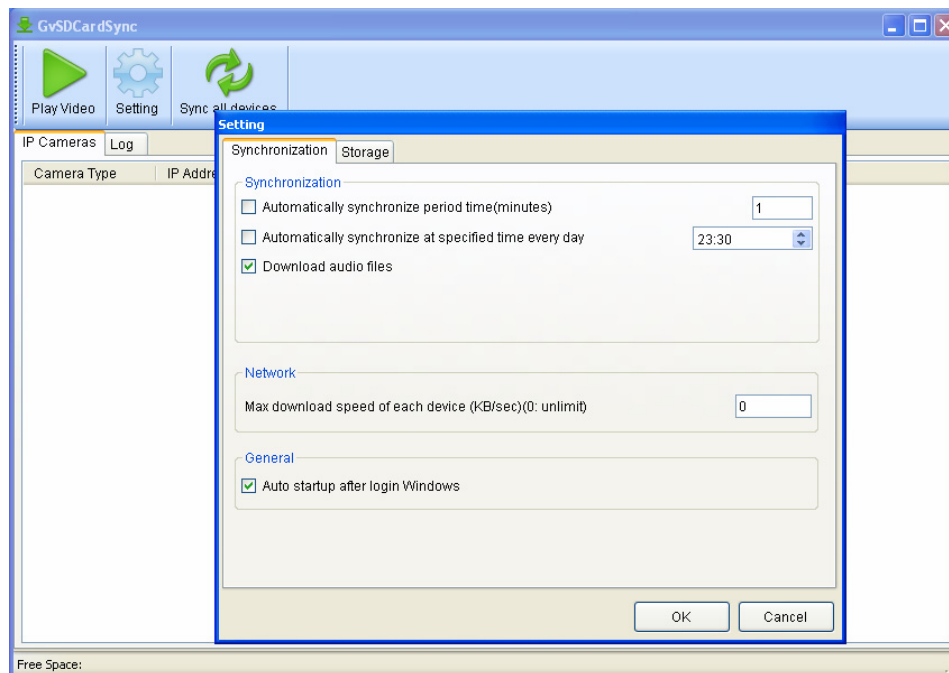

Figure 7-9

- To configure synchronization, network and startup settings, see the steps below.

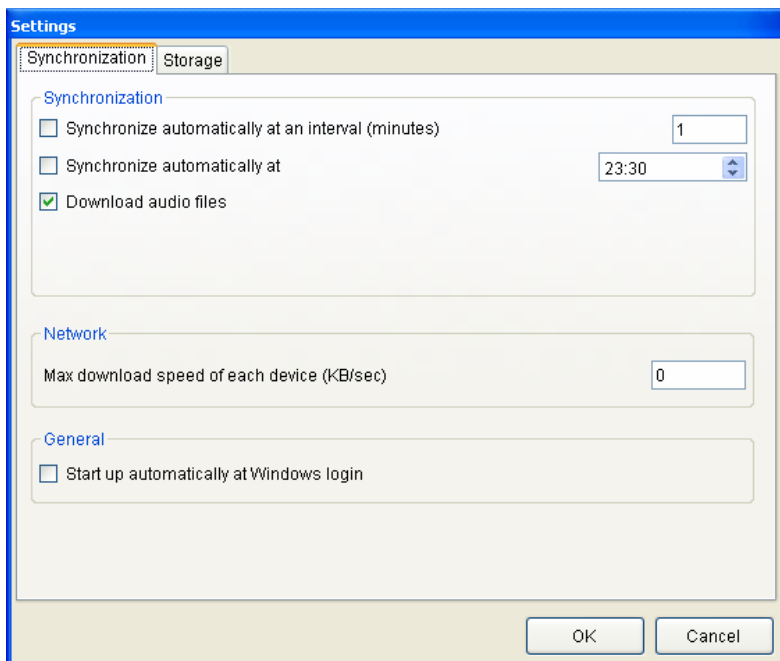

Figure 7-10

[Synchronization]

- **Synchronize automatically at an interval:** Automatically synchronize videos from SD cards to a local folder at the specified interval.
- **Synchronize automatically at:** Automatically synchronize videos from SD cards to a local folder at the specified time.
- **Download Audio Files:** You may choose to download audio files along with the video files. This option is enabled by default.

[Network]

- **Max. download speed of each device (Kb/sec):** To make sure the bandwidth is not completely taken up while downloading files from the memory card, specify a maximum download speed. If you do not want to set a bandwidth limit, type **0**.

[General]

- **Start up automatically at Windows login:** GV-SDSync Utility launches automatically when Windows starts up.

4. By default, downloads are saved to **:\GvSDCardSync** and are not recycled automatically. To configure the storage and recycling settings, select the **Storage** tab on the Setting window. This page appears.

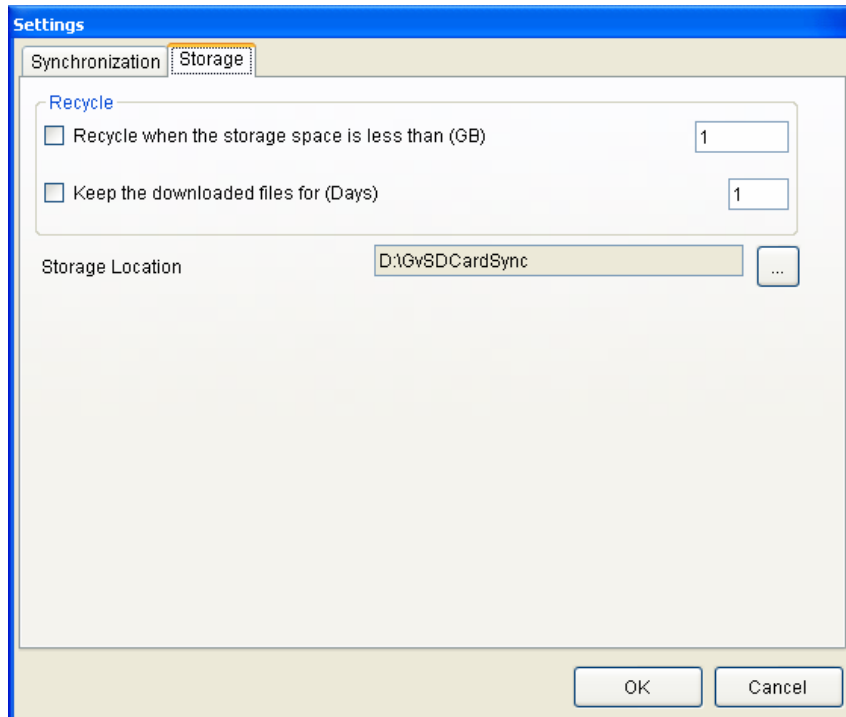

Figure 7-11

[Recycle]

- **Recycle when the storage space is less than (GB):** Specify a minimum free space of your local storage for file recycling.
- **Keep the downloaded files for (Days):** Specify the number of days to keep the download files at the local hard drive.

[Storage Location]

To configure the storage path, click the button next to the location field and specify a storage location.

5. Click **OK** to save the configuration or exit the Setting window.

Note: Keep the GV-SDCardSync Utility running in the background to automatically synchronize and download videos.

7.5.2 The GV-SDCardSync Utility Window

After you have installed the GV-SDCardSync Utility, point to **Start**, select **Programs**, select **GV-SDCardSync** and select  to launch the program. This window appears.

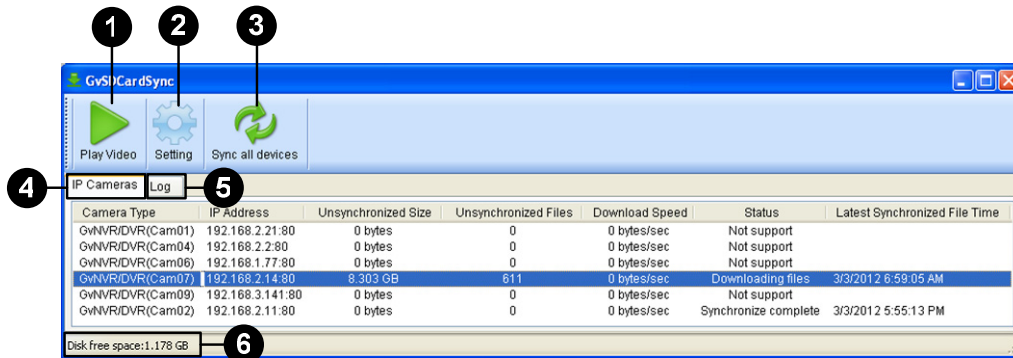

Figure 7-12

No.	Name	Description
1	Play Video	Plays downloaded recordings of the selected GV-IP Speed dome using the ViewLog player. For details, see Chapter 4, <i>DVR User's Manual</i> on GV-NVR Software DVD.
2	Setting	Contains settings on synchronization, network, storage location and recycling criteria. See step 4 in <i>16.5.1 Installing the GV-SDCardSync Utility</i> .
3	Sync all devices	Manually synchronizes and downloads the recording files stored at the GV-IP Speed Dome.
4	IP Camera Tab	Shows information of GV-IP Speed Dome connected to the GV-System, including channel number, IP address, size and number of unsynchronized files, download speed, status and the last synchronization time.
5	Log Tab	Displays up to 100 event entries of the GV-SDCardSync Utility. Once log is full, the oldest file will be deleted first.
6	Storage Space	Shows the storage space of the designated hard drive.

Note:

1. The synchronization time is recorded according to the system time of the GV-IP Speed Dome.
2. The logs are deleted once the GV-SDCardSync Utility is re-activated.

Chapter 8 DVR Configurations

The GV-System provides hybrid solution, integrating the digital videos from GV-IP Speed Dome with other analog videos. For digital videos, the GV-System provides the complete video management, such as video viewing, recording, playback, alert settings and almost every feature of the system. Following is the integration specifications:

- GV-System version **8.5.5.0** or later is required.
- The GV-IP Speed Dome supports up to 5 streams of connection. If the GV-IP Speed Dome is connected through ONVIF, it supports up to 2 streams in total.
- When a GV-IP Speed Dome is connected to IE browser or any other applications, it takes up 1 stream; when it is connected to GV-System, it takes up 2 streams.

Note:

1. The above maximum number of streams is based on the camera's maximum resolution 1920 x 1080 and the codec H.264.
 2. By default, GV-IP Speed Dome is in dual streams and will take up 2 streams when connected to GV-System.
-

- The hardware compression and the "Pre-Recording Using RAM" feature cannot work on the videos from GV-IP Speed Dome. For details about the "Pre-Recording Using RAM" feature, see "System Configuration", Chapter 1, *DVR User's Manual* on the GV-NVR Software DVD.

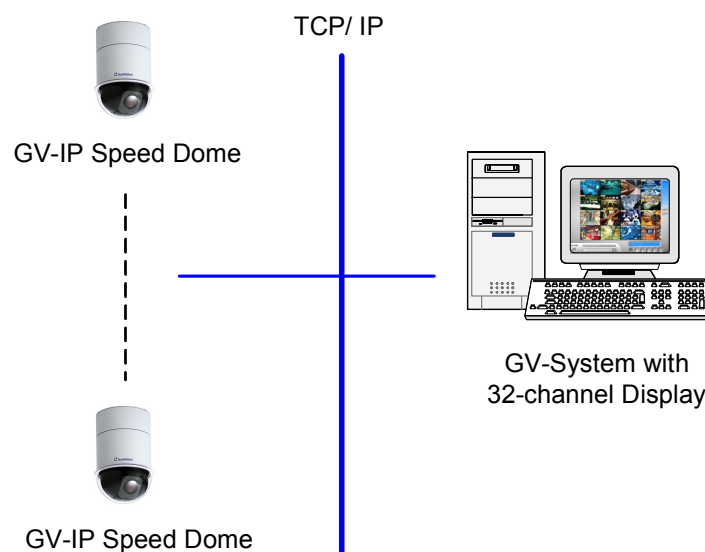

Figure 8-1

8.1 Setting Up IP Cameras

Follow the steps below to manually connect your GV-IP Speed Dome to GV-System.

Note: The following instructions are based on V8.5.5 software and user interfaces.

1. On the GV-System's main screen, click the **Configure** button, select **System Configure**, select **Camera Install** and click **IP Camera Install**. This dialog box appears.

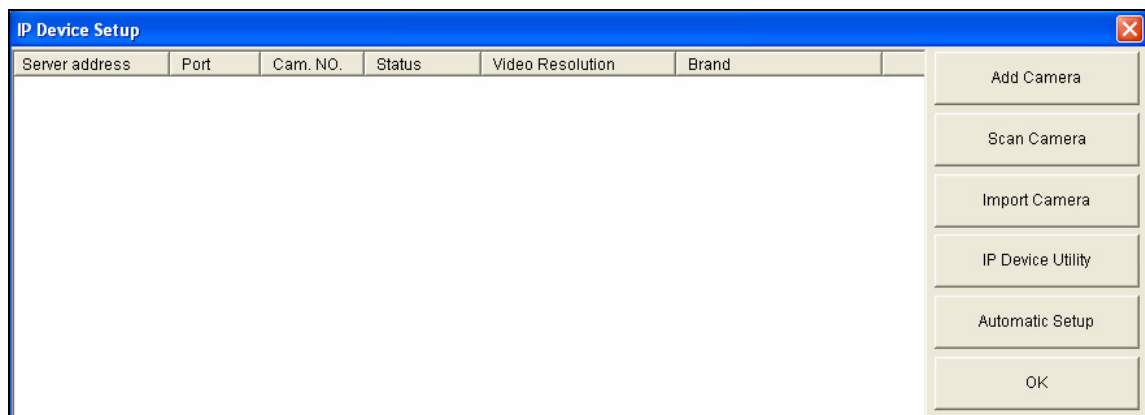

Figure 8-2

- To automatically set up an IP camera, click **Scan Camera** to detect any IP cameras on the same LAN.
- To manually set up an IP camera, click **Add Camera**.
- To import IP cameras from the IP Device Utility, click **Import Camera**.
- To map IP devices through the GV IP Device Utility program, click **IP Device Utility**.
- To add all IP cameras within the IP address range, click **Automatic Setup**.

The following steps are the example of manual setup.

2. Click **Add Camera**. This dialog box appears.

Figure 8-3

3. Type the IP address, username and password of the GV-IP Speed Dome. Modify the default HTTP port if necessary.
4. Select **GeoVision** from the **Brand** drop-down list and select **GV-SD220** from the **Device** drop-down list. This dialog box appears.

Figure 8-4

- **Dual Stream:** Click this button to set the codec type to H.264 in the main stream and the sub stream with the resolutions listed below. **Port:** Modify the video streaming port number if necessary.
 - **Stream Number:** Click the **Query** button and select **Single Stream** or **Dual Stream**.
 - **Codec type:** The live view codec and resolution settings are displayed here.
 - **Resolution:** Select resolutions for preview and recording.
5. Click **Apply**. The GV-IP Speed Dome is added to the list.
 6. Click the listed camera, select **Display position** and select a channel number to map the camera to a channel on the GV-System.

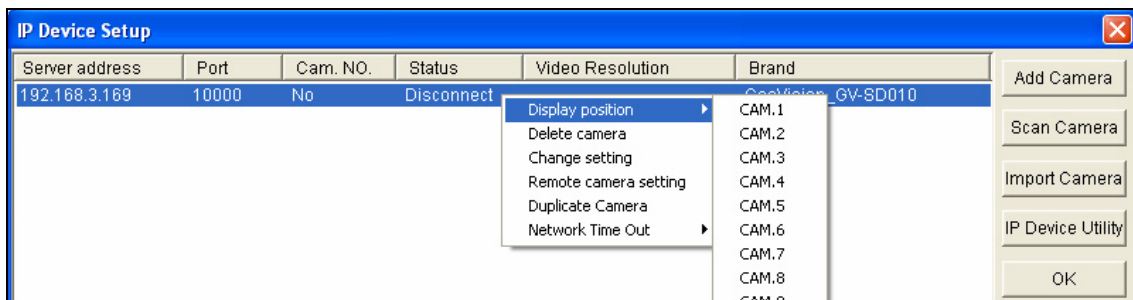

Figure 8-5

7. The Status column now should display “Connected”. Click **OK**. The dome view is displayed on the selected channel of GV-System.

8.1.1 Customizing Camera Settings

After the GV-IP Speed Dome is connected and assigned with a display channel, you can configure the camera's settings such as frame rate, codec type and resolution. Right-click the camera to see the following list of options:

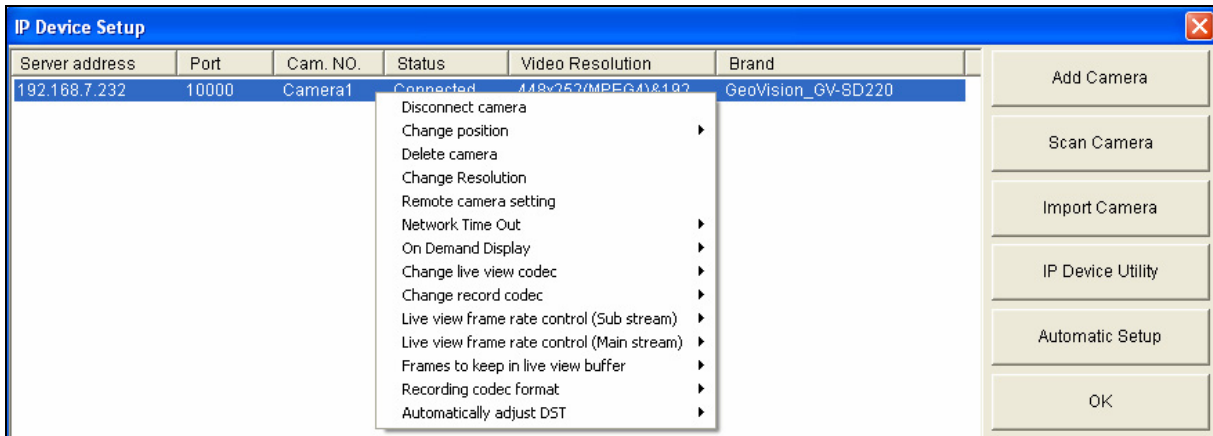

Figure 8-6

- **Change Resolution:** Changes the display ratio, live view resolution and record resolution.
- **Network Time Out:** When network disconnection exceeds the specified time period, the camera status will be displayed as Connection Lost.
- **Change Live View Codec:** Changes the live view codec.
- **Change Record Codec:** Changes the recording codec.
- **Live-view frame rate control (Sub stream):** Sets the live view frame rate of the sub stream to help reduce the CPU usage. If you have set the live view codec to **JPEG**, select the number of frames allowed in a second. If the live view codec is set to **H.264**, select one of the following options:
 - ⊙ **Maximum Live-view Frame Rate:** View the video at the maximum frame rate possible.
 - ⊙ **Live-view Key Frame only:** You can choose to view the key frames of the videos only instead of all frames on the live view. This option is related to the GOP setting of the IP camera. For example, if the GOP value is set to 30, there is only one key frame among 30 frames.
- **Live-view frame rate control (Main stream):** Sets the live view frame rate of the main stream with higher resolution when On Demand function is enabled. Refer to Live-view frame rate control above to see the options available.

- **Image Orientation:** You can adjust the image orientation by selecting **Normal**, **Horizontal Mirror**, **Vertical Flip** or **Rotate 180**.
- **Frames to keep in live view buffer:** Specifies the number of frames to keep in the live view buffer.
- **Recording Codec Format:** Specifies whether to record in standard or GeoVision type of JPEG or H.264 codec.
- **GIS Setting:** Records the video with the GPS data. To record the GPS data, remember to also enable the GIS function of the GV-System (Configure button < Accessories < Enable Local GIS).
- **Automatically Adjust DST:** If enabled, the time on the GV-IP Speed Dome's Web interface will be synchronized with the time of the GV-System when DST period starts or ends on the GV-System.

8.2 Remote Monitoring with Multi View

You can use the Multi View to monitor the video and I/O devices connected to the GV-IP Speed Dome.

Connecting to GV-IP Speed Dome

The Multi View program is available in the GV-System applications, and is also included in the Software CD as an independent program. The following is an example of running the Multi View through WebCam Server on the GV-System.

1. To enable the remote access to the GV-System, click the **Network** button, select **WebCam Server** to display the Server Setup dialog box, and click **OK** to start the WebCam server.
2. At the local computer, open the Web browser and type the IP address of the GV-System. The Single View page appears.
3. Select **Multi View** and the desired viewing resolution. The valid user name and password are required for login. For the first-time user, you will be directed to the Download page. Install the Multi View program before you can run it.
4. On the Multi View window, click the **Edit Host** button. The Edit Host window appears.
5. To create a host, click the **New** button. You need to create a group before creating a host.

6. Select **GV-IP Camera**, **GV-IP Speed Dome** from the Device drop-down list. Type the host name, IP address, user name and password of the GV-IP Speed Dome. Modify the default VSS port **10000** if necessary.

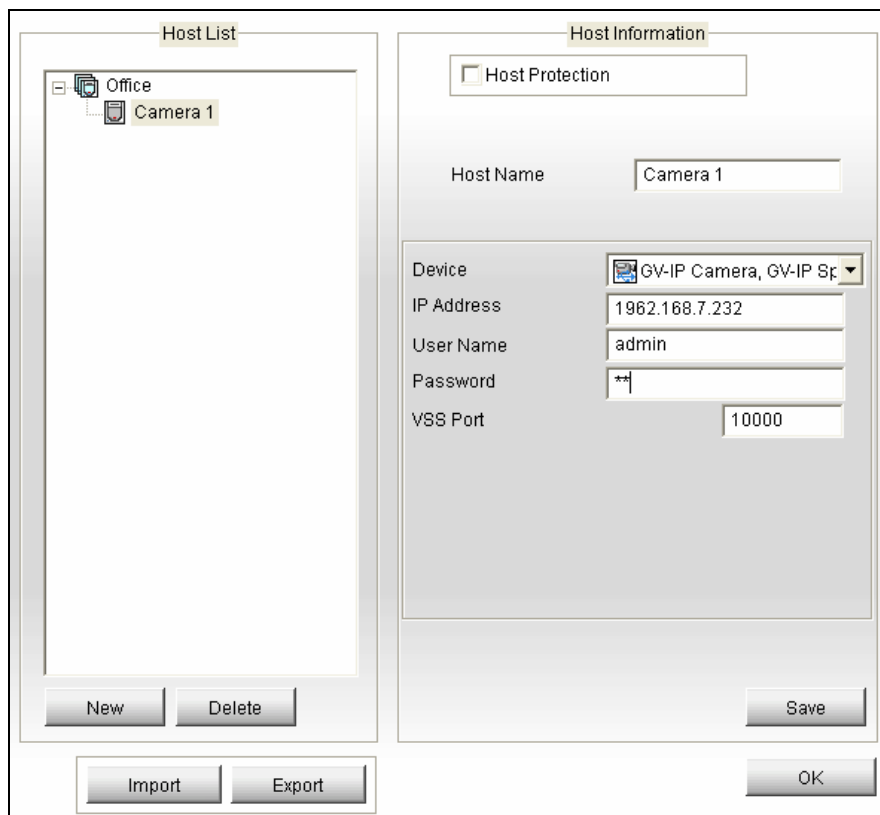

Figure 8-7

7. Click **Save** to establish connection.

For details on the Multi View functions, see “Multi View Viewer”, Chapter 8, *DVR User’s Manual* on the GV-NVR Software DVD.

8.3 Remote Monitoring with E-Map

You can use the Remote E-Map to monitor the video and I/O devices connected to the GV-IP Speed Dome.

Creating an E-Map for the GV-IP Speed Dome

With the E-Map Editor, you can create an E-Map for the GV-IP Speed Dome and I/O devices connected to the dome. The E-Map Editor is available in the two applications: Main System and E-Map Server. The following is an example of running the E-Map Editor included in the Main System.

1. Go to Windows **Start** menu, point to **Programs**, select **GV folder** and click **E-Map Editor**.
2. To create an E-Map, click the **Add Map** button on the toolbar. A New Map file appears.
3. Double-click the New Map file, and click the **Load Map** button on the toolbar to import a graphic file.
4. To create a host, click the **Add Host** button on the toolbar and select **Add Video Server**.
5. Right-click the created New Host in the Host View, and select **Host Settings**. This dialog box appears.

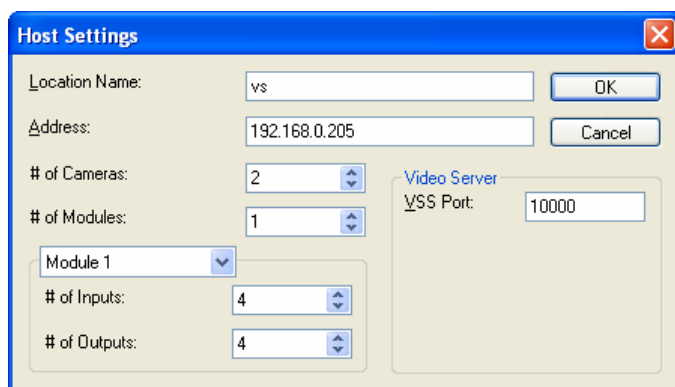

Figure 8-8

6. Give the GV-IP Speed Dome a location name, and type its IP address (or domain name). Keep the default VSS port **10000**, or modify it to match that of GV-IP Speed Dome.
7. Click **OK** to save the settings.
8. Expand the created host folder. Drag and drop the icons of cameras and I/O devices onto the imported E-Map.
9. Close the E-Map Editor. Click **Yes** when you are promoted to save the file.

For details on creating an E-Map file on the E-Map Server, see “E-Map Server”, Chapter 9,

DVR User's Manual on the GV-NVR Software DVD.

Connecting to GV-IP Speed Dome

Depending on where you save the created E-Map file (GV-System, E-Map Server or Control Center), the steps to open the Remote E-Map window for monitoring may vary slightly. The following is the connection example when you store the E-Map file in the GV-System.

1. To enable the remote access to the GV-System, click the **Network** button, select **WebCam Server** to display the Server Setup dialog box, and click **OK** to start the WebCam server.
2. At the local computer, open the web browser and type the address of the GV-System. The Single View page appears.
3. Select **Remote eMap**. The valid user name and password are required for login. For the first-time user, you will be directed to the Download page. Install the E-Map program before you can run it.
4. On the Remote E-Map window, click the **Login** button and select the GV-IP Speed Dome host to access its videos and I/O devices. The valid user name and password are required to log in the GV-IP Speed Dome.

For details on the Remote E-Map functions, see “The Remote E-Map Window”, Chapter 9, *DVR User's Manual* on the GV-NVR Software DVD.

Chapter 9 CMS Configurations

This section introduces the related settings to enable connecting to the GV-IP Speed Dome in the central monitoring stations Center V2 and VSM and Dispatch Server.

9.1 Center V2

The Center V2 can monitor the video and I/O devices connected from the GV-IP Speed Dome.

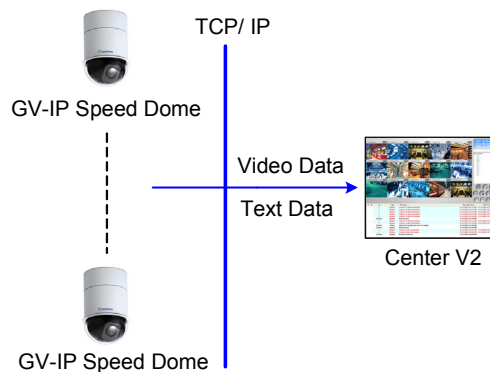

Figure 9-1

- To set the appropriate port connecting to the GV-IP Speed Dome, click the **Preference Settings** button, select **System Configure**, click the **Network** tab, and check **Accept connections from GV-Compact DVR, Video Server & IP Cam**. Keep the default port **5551** for the Port 2 option, or modify it to match the Center V2 port on the GV-IP Speed Dome.

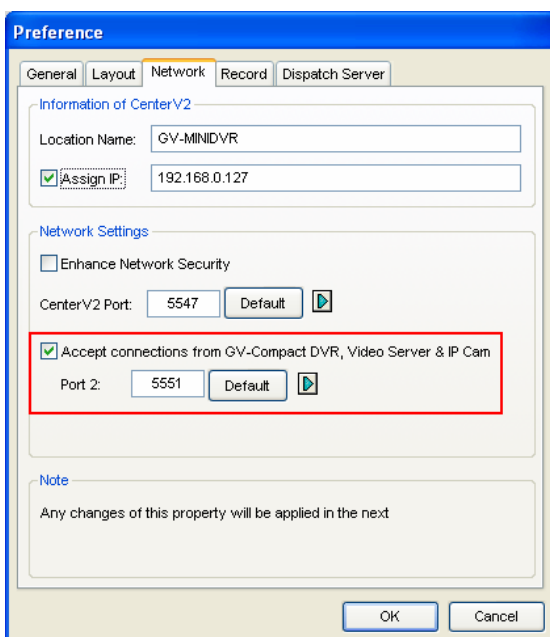

Figure 9-2

- To define how to display the received video on motion detection and input trigger from the GV-IP Speed Dome, click the **Preference Settings** button and select **System Configure**. This dialog box appears.

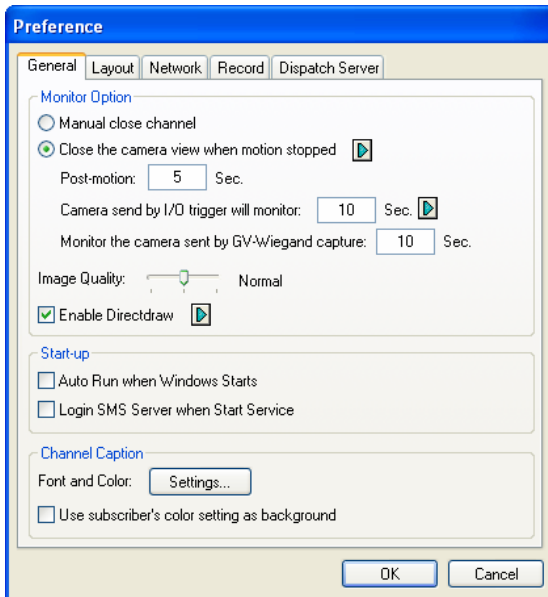

Figure 9-3

- **Manual close channel:** Closes the triggered camera view manually.
- **Close the camera view when motion stopped:** Closes the triggered camera view automatically when motion stops.
- **Post Motion:** Specify the duration of the camera view remaining on the monitoring window after motion stops.
- **Camera send by I/O trigger will monitor:** Specify the duration of the camera view remaining on the monitoring window when an I/O device is triggered.

To keep the camera view remaining on the monitoring window even after the alarm is finished, click the right-arrow button, and uncheck **Latch Trigger**. Then the dome view will remain on the monitoring window for the specified time. For example, the alarm is triggered for 5 minutes and you set 10 minutes, which means the total display time will be 15 minutes.

For further information on how to manage the received video from the GV-IP Speed Dome, see *GV-CMS Series User's manual*.

9.2 VSM

The VSM can monitor the video and I/O devices connected from the GV-IP Speed Dome.

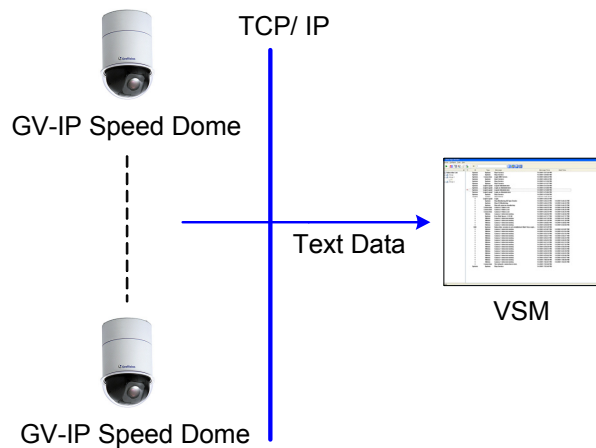

Figure 9-4

- To set the appropriate port connecting to the GV-IP Speed Dome, click **Configure** on the window menu, and select **System Configure** to display this dialog box. In the Connective Port field, keep the default value **5609** for the Port 2 option, or modify it to match the VSM port on the GV-IP Speed Dome.

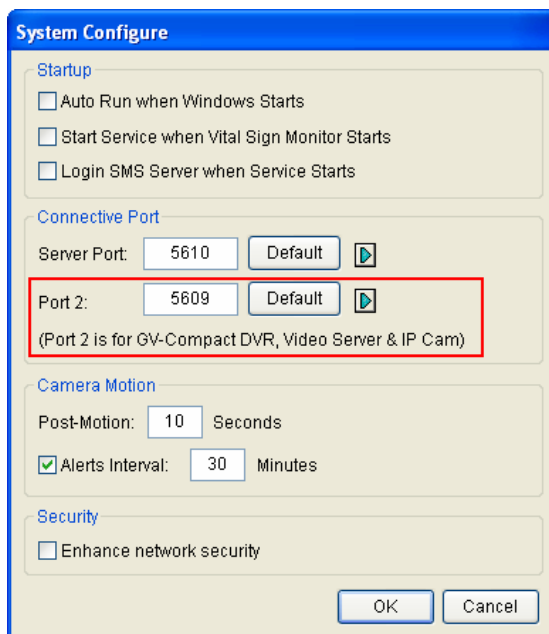

Figure 9-5

For further information on how to manage the received video from the GV-IP Speed Dome, see *GV-CMS Series User's manual*.

9.3 Dispatch Server

The Dispatch Server can manage the video and I/O devices connected from the GV-IP Speed Dome, and distribute them to the Center V2.

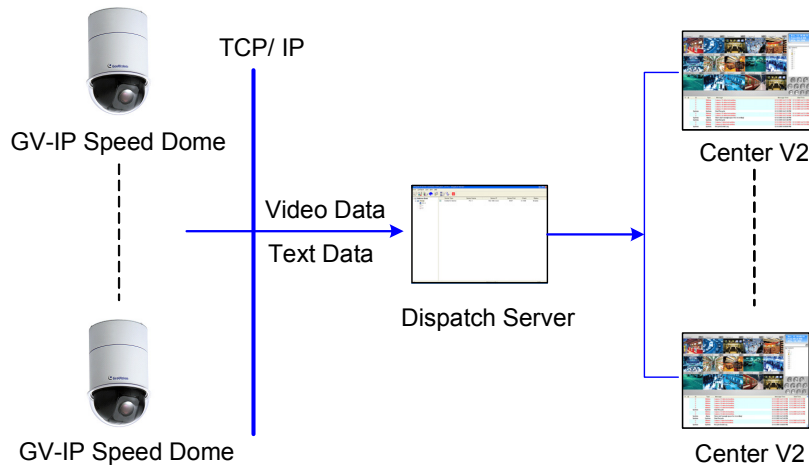

Figure 9-6

- To enable connecting to the GV-IP Speed Dome, click the **Server Setting** button on the toolbar, and enable **Allow Video Server Login as Subscriber from Port**. Keep the default port **5551**, or modify it to match the Center V2 port on the GV-IP Speed Dome.

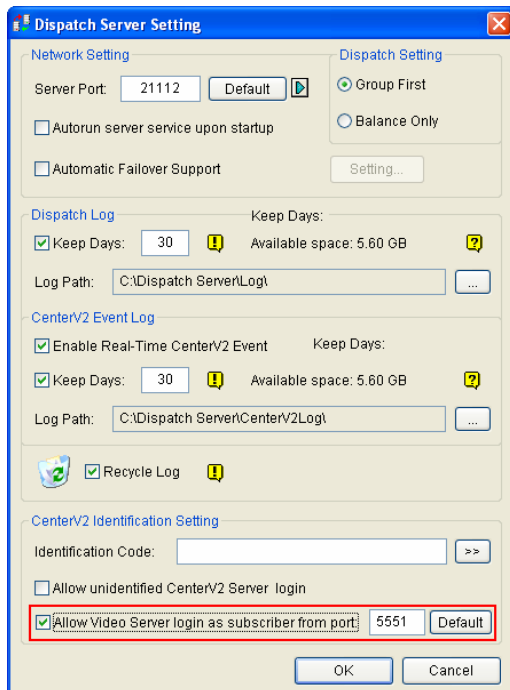

Figure 9-7

For further information on how to manage the received video from the GV-IP Speed Dome, see *GV-CMS Series User's manual*

Chapter 10 Smart Device Connection

Using Android or Apple smart devices, you can receive live video streaming from the GV-IP Speed Dome. The charts below list the GV mobile applications supporting the GV-IP Speed Dome.

Smart Device View	OS Supported	Default Port
GV-Eye (HD) V1.2.0	Android V2.2 to 4.0.4 iOS 4.3.3 to 5.1	VSS Port: 10000

Chart 1

Note: When users try to connect to the GV-IP Speed Dome via these mobile applications, they can access the live view, I/O control and PTZ control functions. The remote playback function is not available.

Supported Resolution and Codec	
Smart Device View	GV-Eye V1.2.0 (HD)
MJPEG	1920 x 1080 or below
H.264	

10.1 Android

Download GV-Eye from Android Market and install the application. The GV-Eye icon will appear on the desktop.

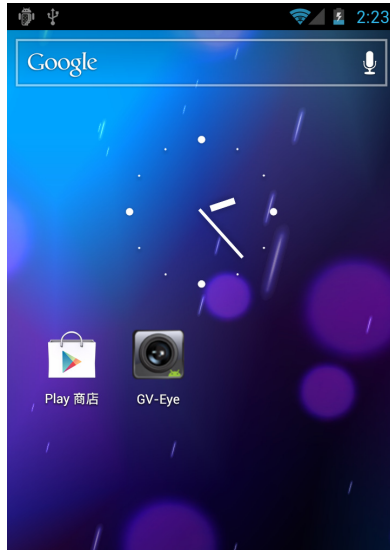



Figure 10-1

10.1.1 Connecting to GV-IP Speed Dome

1. Tap the **GV-Eye** icon  on your device, and then this page appears.

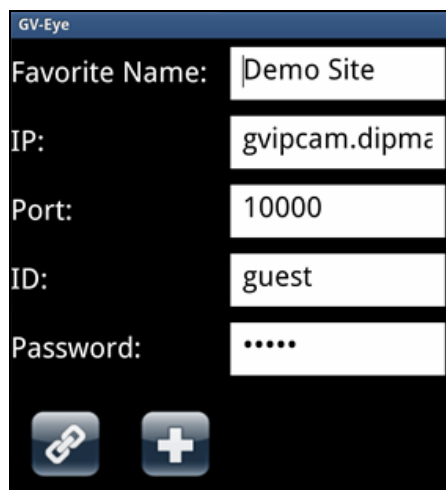



Figure 10-2

2. Type the IP address, port number (default value is 10000), user name and password of the GV-IP devices you want to access. And then tap the **Add** button  to save the connection information in the address book.
3. Tap the created link in the address book.

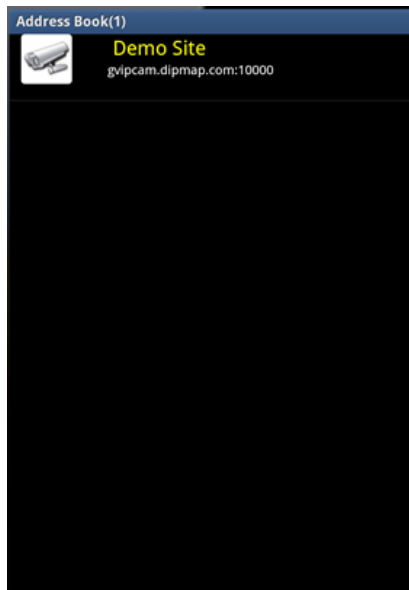

Figure 10-3

4. Tap the **Connection** button  to access the GV-IP devices.

10.1.2 Accessing Live View

You can press the Menu button on the mobile phone to see or hide the connection information.

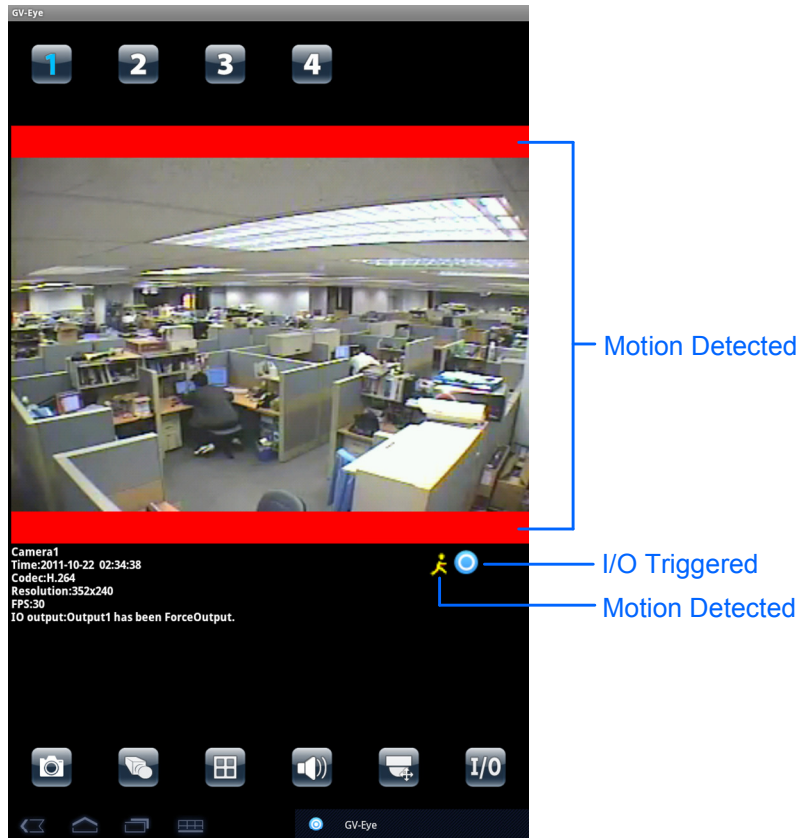



















Figure 10-4

The following function buttons are available:

Icon	Name	Function
	Channel number	Switches to a different channel. You can drag across the numbers to see more channels. This function is only supported by GV-Video Server and GV-Compact DVR.
	Snapshot	Saves the current image in the mobile device
	Dual Stream	Switches between the video streams if the GV-IP device supports dual streams.
	Screen division	Displays up to four channels on the same page if the GV-IP device supports multiple channels. This function is only supported by GV-Video Server and GV-Compact DVR.

Icon	Name	Function
	Audio	Enables or disables the audio function. G.711 and G.723 audio codec are supported.
	PTZ Control	<p>Enables the PTZ function. A message will appear asking if you want to use Gesture Detector to control PTZ. Tap OK if you want to be able to drag across the live view screen to control the PTZ function in addition to using the PTZ control buttons on the bottom of the screen.</p> <ul style="list-style-type: none"> : Moves the camera toward different directions. : Moves the camera back to Home position. : Zooms in and out. : Adjusts the focus. : Auto adjusts focus. : Adjusts the iris. : Moves the camera to a preset point by typing the preset number. : See more PTZ function buttons. : Exits the PTZ mode.
	I/O Device	Tap a number to force the output device to be triggered. The I/O icon  will appear briefly when I/O is triggered.

Note: The default live view is stream 2, limited to **Admin** users only in GV-Eye V1.2.0.

10.2 Apple

Download GV-Eye / HD from **App Store** and install the application. The **GV-Eye / GV-EyeHD** icon will appear on the desktop.

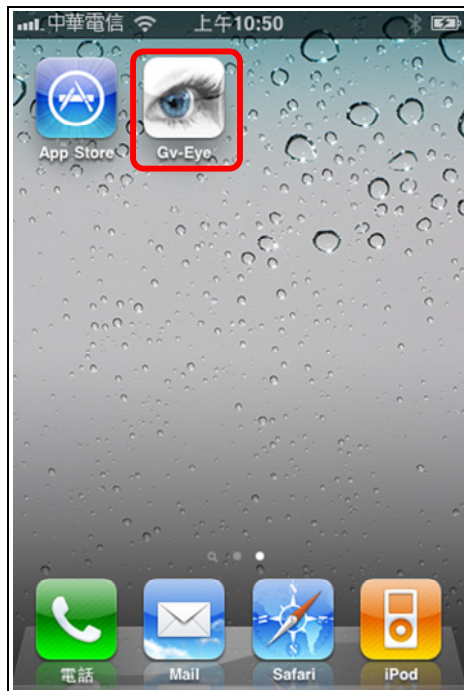

GV-Eye icon on iPhone / iPod Touch

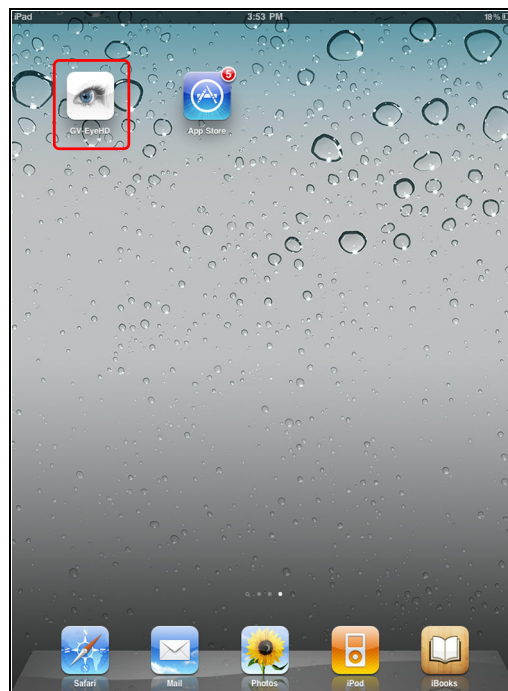



GV-Eye HD icon on iPad

Figure 10-5

10.2.1 Connecting to GV-IP Speed Dome

To connect your iPhone, iPod Touch or iPad to the GV-IP Speed Dome, follow these steps:

1. Click the **GV-Eye** icon  on the desktop of your phone. The welcome page appears.
2. Tap the **Add** button . This page appears.

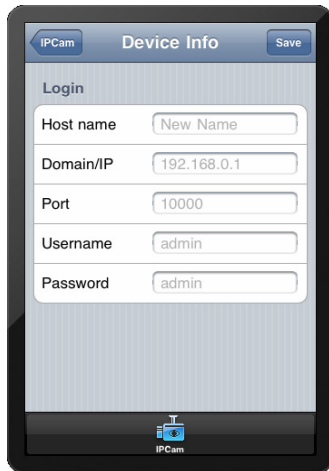

Figure 10-6

3. Enter the Host name, Domain/IP address, port number (default value is 10000), username and password to log in to the GV-IP Speed Dome.
4. Tap the **Save** button. The GV-IP Speed Dome is now added to the IPCam list and will be available the next time you access GV-Eye. You can tap the **Edit** button and then select an IP speed dome to edit existing device login information.

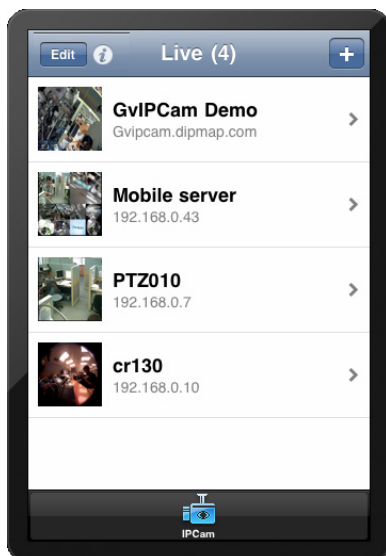



Figure 10-7

10.2.2 Accessing Live View

You can tap the information button  at the top-right corner to see the connection information.

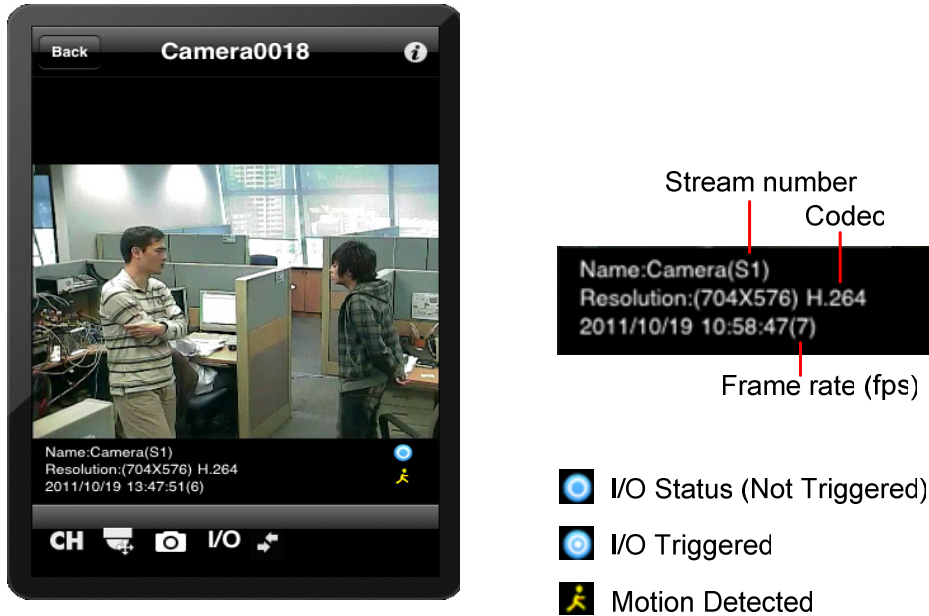













Figure 10-8

The buttons below are available when the iPhone, iPod Touch or iPad is positioned vertically.

Icon	Name	Function
	Screen division	Displays up to four channels on the same page if the GV-IP device supports multiple channels.
	PTZ control	Enables PTZ control. Drag across the camera live view screen to adjust the camera position. The following buttons are available: <ul style="list-style-type: none"> : Zooms in and out. : Adjusts the focus. : Moves the camera back to Home position. : Adjusts the iris. (GV-SD010 only) : Moves the camera to a preset point by typing the preset number.
	Snapshot	Saves the current image in the mobile device.
	I/O Device	Tap a number to force the output device to be triggered. The I/O icon  will be highlighted briefly when I/O is triggered.
	Stream change	Switch the live view streams.

Note:

1. The PTZ control and I/O device functions are only accessible on devices with PTZ control and I/O devices.
 2. The default live view is stream 2, limited to **Admin** users only in GV-Eye (HD) V1.2.0.
-

GV-IP Speed Dome Specifications

Camera		
Image Sensor	1/2.8" CMOS	
Optical Zoom	20x	
Digital Zoom	12x	
Effective Pixels	2M	
Horizontal Resolution	Digital Interface	
Scanning System		
Synchronization		
Video Output	Internet	
S/N Ratio	> 50 dB (AGC Off)	
Minimum Illumination	0.5 Lux (1/30 sec), high sensitivity 1.7 Lux (1/30 sec), typical	
Focal Length	4.7 ~ 94.0 mm	
Focus Mode	Auto / Manual	
White Balance	Auto / Manual	
Iris Control	Auto / Manual	
Electronic Shutter	1/1 ~ 1/10 Ks	
AGC Control	Auto / Manual	
Back Light Compensation	On / Off	
WDR pro	Yes	
Video		
Video Codec	H.264, MJPEG	
Video Resolution	16:9	1920 x 1080, 1280 x 720, 640 x 360, 448 x 252
Frame Rate	30/25 fps (60/50 Hz) at 1920 x 1080 60/50 fps (60/50 Hz) at 1280 x 720	
Audio		
Audio Input/Output	2-way audio, stereo jack, Ø 35 mm	
Audio Codec	G.711, AAC (16 kHz / 16 bit)	
Network		
Interface	10/100 Base-T Ethernet, RJ-45 connector	
Protocol	DHCP, DynDNS, FTP, HTTP, HTTPS, NTP, ONVIF, QoS (DSCP), RTSP, SNMP, SMTP, TCP, UDP, UPnP, 3GPP/ISMA	

Mechanical		
Temperature Detector		Yes
Connectors	Power	DC Jack
	Local Storage	Micro SD / SDHC / SDXC memory card slot (for Class 6 or above)
	Digital I/O	I/O wires
Web Interface		
Installation & Management		Web-based configuration
Firmware Upgrade		Remote upgrade through Web Browser IP Device Utility included in the Software CD
Access from Web Browser		live view, video recording, PTZ control, Preset, Sequence, Cruise, Auto Pan, Tour, image quality settings, bandwidth control, image snapshot, I/O control, 2-way audio, Picture-in-Picture (PIP), Picture-and-Picture (PAP), Wide Angle Lens Dewarping (WALD), Text Overlay, image masking
Language		Arabic / Bulgarian / Czech / Danish / Dutch / English / Finnish / French / German / Greek / Hebrew / Hungarian / Indonesian / Italian / Japanese / Lithuanian / Norwegian / Persian / Polish / Portuguese / Romanian / Russian / Serbian / Simplified Chinese / Slovakian / Slovenian / Spanish / Swedish / Thai / Traditional Chinese / Turkish
Operation		
Pan Travel		360° endless
Tilt Travel		0° ~ 90°
Movement Speed		0.5° ~ 460°/s
Calibration		Auto / Manual
Preset	Max. Number	255
	Accuracy	0.2°
Sequence	Max. Number	8
	Max. Number of Presets	16
Auto Pan		8
Cruise		4

Tour	Max. Number	8
	Max. Number of Preset / Sequence / Auto Pan / Cruise	16
Privacy Mask		8
Proportional Pan & Tilt		On / Off (Pan and tilt speed proportional to zoom ratio)
Automatic Function		Preset, Sequence, Auto pan, Cruise, Tour
Mechanical Flip		On / Off
Digital Slow Shutter		On / Off
Motion Detection		On / Off
Day/Night: Mechanical IR Cut Filter		On / Off
Image Inverse		On / Off
Image Freeze		On / Off
Alarm	Input	4
	Output	1
	Reaction	Preset, Sequence, Auto pan, Cruise, Tour
General		
Operating Temperature	Indoor	-10°C ~ 50°C / 14°F ~ 122°F
	Outdoor	-40°C ~ 50°C; -40°F ~ 122°F
Humidity		20% ~ 90% (non-condensing)
Waterproof Standard		IP66 standard (GV-SD220-S only)
Dimensions	Indoor	Ø177 x 221.9 mm / 7 x 8.8 in
	Outdoor	Ø220 x 297.75 mm / 8.7 x 11.7 in
Weight	Indoor	3.2 Kg / 7.1 lb
	Outdoor	4.7 kg / 10.4 lbs
Power Source		24V AC ± 10%, 3A / 24V DC ± 10%, 3.75A
Power Consumption	Indoor	30 W
	Outdoor	60 W (with 30W heater)
Heater (Outdoor model only)		Heater 1 On: 5°C/41°F; Off: 8°C/46.4°F Heater 2 On: -7°C/19.4°F; Off: -2°C/28.4°F
Fan (Outdoor model only)		On: 45°C/113°F (or <5°C/41°F for heater)
Fan-On Threshold		35°C / 95°F
Regulatory		CE, FCC, RoHS

Applications	
Network Storage	GV-NVR, GV-System, GV-Recording Server
Smart Device Access	- GV-Eye for Android smartphone, tablet, iPhone and iPod Touch - GV-Eye HD for iPad
Live Viewing	IE, Mobile Phone
CMS Server support	GV-Control Center, GV-Center V2, GV-VSM, GV-GIS

All specifications are subject to change without notice.

Appendix

A. The CGI Command

With GV-IP Speed Dome, you can obtain a snapshot of the live view or access the User Account Web interface simply by executing CGI commands. For a GV-IP Speed Dome with the following details:

IP address: 192.168.2.11

Username: admin

Password: admin

Desired Stream: 1

- To obtain a snapshot of live view, type the following into your web browser:

<http://192.168.2.11/PictureCatch.cgi?username=admin&password=admin&channel=1>

- To access the User Account settings on the Web interface, type the following into your web browser:

<http://192.168.2.11/ConfigPage.cgi?username=admin&password=admin&page=UserSetting>

B. RTSP Protocol Support

The GV-IP Speed Dome supports RTSP protocol for both video and audio streaming. For RTSP command, enter:

```
rtsp://<IP of the GV-IP Speed Dome:8554/<CH No.>.sdp
```

For example, `rtsp://192.168.3.111:8554/CH001.sdp`

Note:

1. The RTSP streaming provides source video images of 352 x 240 / 352 x 288 only.
 2. The RTSP server must be enabled on the Web interface. See Figure 5-14.
 3. Only VLC and QuickTime players are supported for streaming video via RTSP protocol.
-

C. Settings for Internet Explorer 8

If you use Internet Explorer 8, it is required to complete the following setting.

1. Set the Security to **Medium-high (default)**.
2. Enable **Allow previously unused ActiveX controls to run without prompt**.
3. Disable **Only allow approved domains to use ActiveX without prompt**.

